

Probe temperature STF / STPR

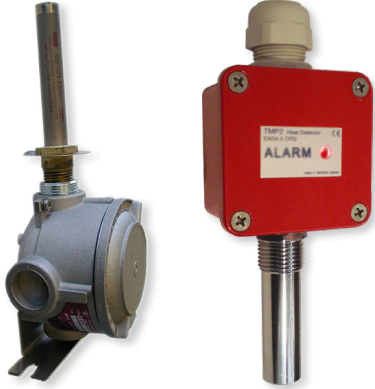

Punctual heat detector based on a probe that allows its installation in special environments.

Depending on the protection needs, the detector can be used in:

- Aggressive environments: Model IP65.
- ATEX environments: II2GD Exd IIC T6.

TECHNICAL FEATURES	
Protection	IP65
Relative humidity	98%
Weight	400gr
Bi-metal component	Nilvia (Nilvar)
Sensor material	Steel
Fixed calibration on request (°C)	60 - 71 - 88 - 107 - 135 - 163 - 182 - 232 - 315 - 385

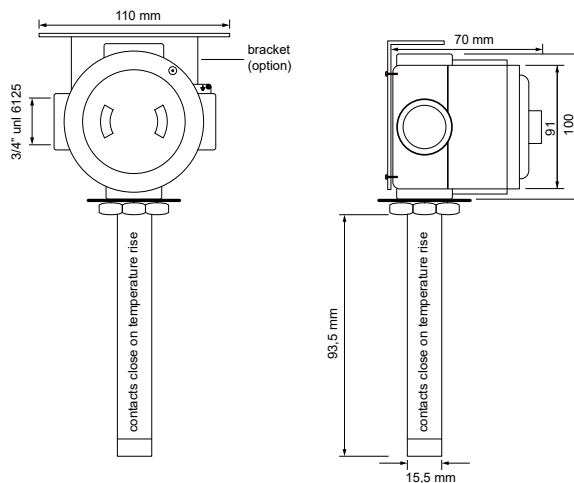

ALGORITHMIC ADDRESSABLE SYSTEM

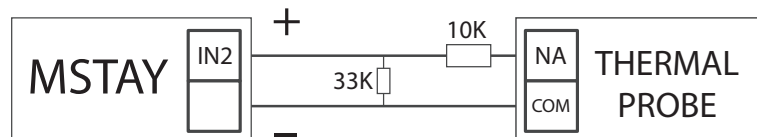

CONVENTIONAL SYSTEM

