



CTE / CTX

LINEAL HEAT DETECTOR

Lineal heat detector for fire protection installations

Linear heat Detector is a proprietary cable that detects the heat at any point of its length.

The sensor cable consists of two steel conductors individually insulated with a polymer sensitive to temperature. The insulated conductors are twisted together to create a spring pressure, then is wrapped with an outer cover appropriate to the environment in which must be installed in the detector.

In the calibrated temperature, heat sensitive insulating polymer yields against the pressure generated by the radiation of heat,

allowing interior conductors get in touch between them and activate an alarm signal. This action occurs at any point heated within the detector cable length. It is not required to heat a specific length to activate the alarm, or you need to calibrate the system to compensate for changes in environmental temperature where it is installed.

The linear heat Detector provides the advantages of coverage of lines with sensitivity of specific points.

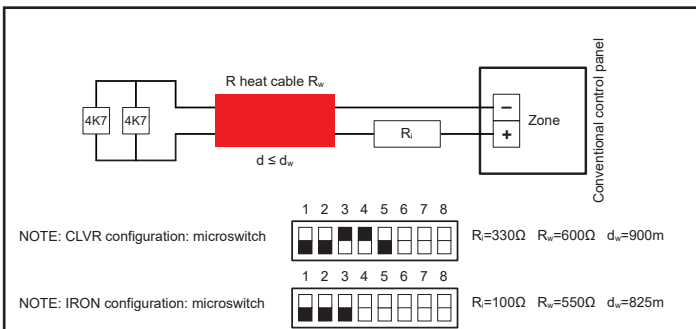

Wiring diagram with direct connection to the conventional control panel

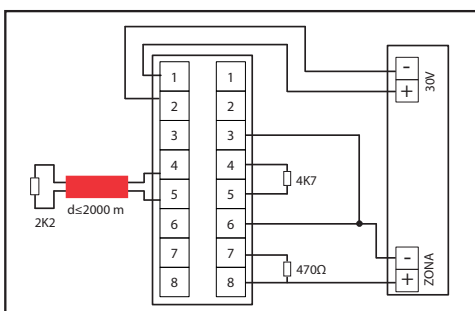

Wiring diagram with interface module

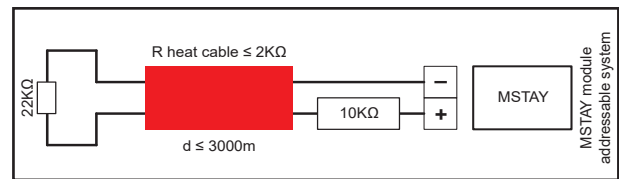

Wiring diagram with direct connection to addressable module MSTAY

Product type	Alarm T°C	Max environ.T°C
EPC Various utilities/ Industrial and commercial applications	68 °C	38 °C
	78 °C	56 °C
	88 °C	66 °C
	105 °C	79 °C
	138 °C	93 °C
XCR Industrial applications excellent resistance to the chemical abrasion	180 °C	105 °C
	68 °C	38 °C
	88 °C	66 °C
	105 °C	79 °C
XLI Excellent for low T°C	138 °C	93 °C
	180 °C	121 °C
	57 °C	38 °C

Temperature and product type evaluation

TECHNICAL FEATURES	
Max. nominal voltage	30VAC, 42VDC
2W wire resistance	0,2 ohms / pie. (0,656 ohm / m)
Min. radius of curvatures	6,4cm
Diameter	Nominal 4mm
Weight	Nominal 3,5kg / 152m