

TECHNICAL CATALOGUE

Addressable system

Conventional system

Detection complements



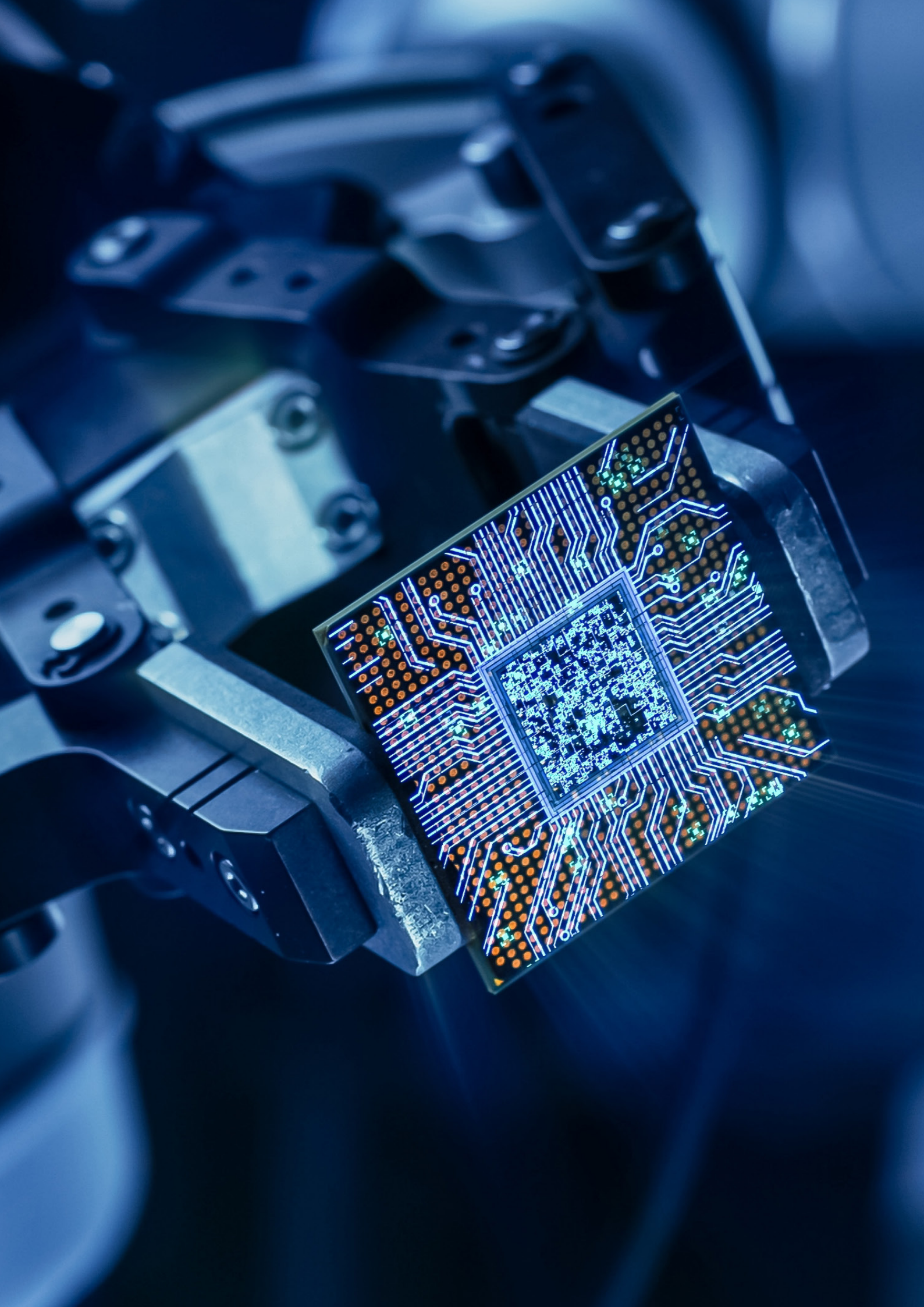

TECHNOLOGY THAT PROTECTS

Founded in 1973, Cofem is the leading designer and manufacturer of advanced fire protection systems. With half a century of experience, we are pioneers in integrating cutting-edge technology into solutions ranging from intelligent detection and alarm systems for buildings to innovative gas monitoring devices.

Our dedication to quality and innovation has led us to obtain prestigious international certifications and to consolidate our presence in more than 50 countries. The combination of experience, proprietary technology and a focus on constant development positions us as a global benchmark in advanced fire safety.

At Cofem, we redefine security for a more reliable and connected future.

INDEX

Addressable system

Conventional system

Detection complements





ADDRESSABLE SYSTEM

The Algorithmic addressable Fire Detection System represents the most modern technology in fire detection and constitutes a natural evolution from the Identifiable Detection System towards equipment that not only is able to identify the element that produces the alarm (sensor or call point), but that also allows for the total configuration of detection parameters (alarm levels, sensibility,...) as well as the adaptation to the environmental conditions and the degree of dust in the sensor.

In the Cofem Algorithmic addressable Detection System, the loop elements (sensors, manual call points, relay modules, masters, analogue sounders and technical signal module) have the property of being auto-identifiable, that is to say, all of them can be installed with no need for prior manual encoding, facilitating enormously the assembly and subsequent modifications to the installation.

The Algorithmic addressable Detection System is based on the measurement and transmission of the instant value of the monitored magnitude (smoke, temperature or monoxide concentration), for their subsequent processing in the control panel, which will consider the alert or standby status of the sensor. Each sensor incorporates a microprocessor responsible for the digitalization of the analogue value read in the sensor, for transmission of this value to the control panel and for identification of the sensor.

The main difference between the conventional and analogical detection systems lies in that for the first the Voltage delivered by the transducer is compared with a predetermined and fixed threshold (V_{alarm}), obtaining from that comparison the system in standby or system in alarm status.

In the Algorithmic addressable Detection System, on the contrary, the control panel gathers the readings from each sensor and determines the status thereof according to these readings, any previous readings (history), the pre-programmed parameters and on the decision algorithm, being possible to act on the detection parameters, as well as, for example, the alarm threshold.

Each sensor on the Cofem Algorithmic addressable Detection System transmits its value to the control panel with a regularity of less than 10 seconds.



COFEM360

REMOTE COMMUNICATION SYSTEM

Cofem360 remote communication system

System for algorithmic-addressable control panels with Onix, Quartz and Rubí references, and the conventional Silver control panel.

It enables remote connection of the fire detection and alarm control panel to the cofem360 app, available for mobile devices running iOS and Android, provided there is an internet connection.

Setting up the system is quick and easy: simply download the app from the App Store or Google Play and scan the QR code on the control unit. The control panel will then be linked to the mobile device user.

The app allows users to receive notifications regarding alarms, faults, actions, etc., from the control panels linked to their account, and to access the control panel's management interface directly. It also allows users to access the management interface of any control panel linked to their account, view the latest events, and perform actions such as 'silencing sirens', 'resetting the control panel', 'activating/stopping the evacuation', etc.

The system is an essential tool for installers and maintenance technicians during commissioning, maintenance work, remote customer support, or even for those responsible for the installation or the end customer.



FEATURES

- For Onix, Quartz, Rubí and Silver control panels.
- Access via the cofem360 app, available for iOS and Android.
- Quick and easy setup by scanning a QR code from the control panel.
- Receive notifications from the control panel and access its control panel.
- A useful tool for commissioning, maintenance, customer support or incident management by the person in charge of the installation or the end customer.

NOTE: The features available in the product will depend on the version



COFEM RMS

REMOTE MANAGEMENT SYSTEM

Remote management system for the fire detection system

Remote Touch Display to be installed in the premises or building that allows the management of the incidents of the fire detection and alarm system with a very reduced training of the personnel.

The display is designed to be placed in an accessible place for the personnel responsible for the installation, allowing a very simple, clear and intuitive visualisation of the alarms, faults and disconnections of the fire detection and alarm system.

In case of events, the user can perform immediate predetermined actions according to the reported events, such as resetting the event, stopping the sounders or evacuation.

Due to its simplicity in the presentation of information and action on the events, the staff needs very little training to use it, which makes it very practical, useful and effective in emergency and stress situations.

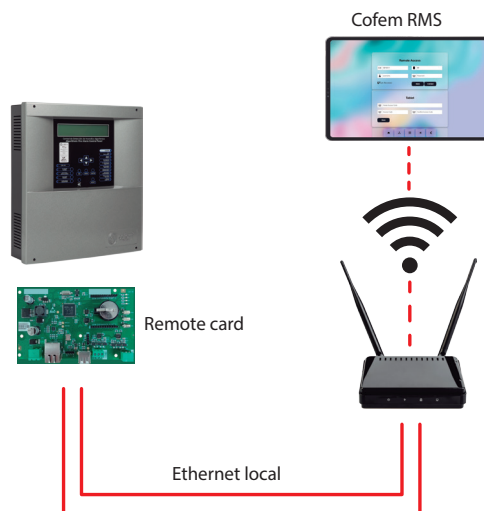



LYON REMOTE

ADDRESSABLE ALGORITHMIC CONTROL PANEL

Lyon Remote addressable algorithmic control panel for fire detection and fire alarm, certified according to EN 54-2 and EN 54-4

The Lyon algorithmic addressable Control Panel is EN 54-2 and EN 54-4 standard certified according to the latest CE Directives/Regulation and can successfully overcome difficult environmental conditions, electrical interferences, electromagnetic radiate upsets, vibrations, etc.

The algorithmic addressable Detection System is able to identify the device which produces the alarm or fault (sensor or call point), and allows the total configuration of the detection

parameters (alarm levels, sensibility...) as well as the adaptation to the environmental conditions and the degree of dust in the sensor.

In the Cofem algorithmic addressable System, the loop elements (sensors, manual call points, relay modules, masters, analogue sounders and technical signal modules) have the property of being auto-identifiable, that is to say, all of them can be installed with no need for prior manual encoding, facilitating enormously the assembly and subsequent modifications to the installation.

FEATURES

- Control panel configurable and expandable up to 8 loops (226 points per loop).
- Expandable up to 20 loops with an additional cabinet.
- All the points are supervised by the control panel, except the loop isolator KABY.
- Capacity for 64 relays per loop and 199 in total.
- Can hold up to 99 zones per panel.
- Registry with capacity of 3308 events with date and time.
- Relay configuration with activation of 1, 2 or 3 alarm detectors.
- Relay activation auto-configuration function.
- Allows the configuration of visual and/or sound devices of the detector bases as loop powered relays.
- Delay of supervised sounder output prog. between 0 to 10 minutes, identified as S1.Total load Max: 2A/28,8Vdc.
- Alarm output as free voltage relay not supervised, identified as S2.
- Failure output delayable, identified as S3.
- Allowed to connect addressable sounders in the loop.
- Evacuation push-button.
- Backlit LCD display with 4 lines and 40 characters.
- Incorporates multiple languages by default (Spanish, English, French, Portuguese, etc).
- Configurable with the I-Link software.
- Access to the control panel keyboard introducing a numeric code.
- Allows connection of up to 15 repeaters and/or 15 control panels in network.
- MODBUS (on specific request).
- CRI functionality on demand.
- Cofem Remote.
- Size: 424 x 330 x 160 mm (with cover).
- Certified according to EN 54-2 and EN 54-4 and CE mark according to the European Regulation of Construction Products (UE) N° 2024/3110.

TECHNICAL FEATURES

Input voltage	110/230 Vac 50/60Hz	Maximum current per loop	500mA/25 at 32V/DC
Output voltage	21V nominal	Communications port	USB 2.0/1.1 type B
Max. consumption	155VA at 230 VAC		RS232/RS485
Power fuse	8A	Environmental conditions	-10°C+50°C 20%-95%RH
Battery charger	Yes	Dimensions	424x330x160mm (with cover)
Devices per loop	226	Weight (without batteries)	7,4kg
Power supply	5A	Standard	EN 54 parts 2 and 4
Fuse S3	1A	Fuse S1	2A
IP protection	IP30	Output fuse 30V	2A



ONIX

ADDRESSABLE ALGORITHMIC CONTROL PANEL

ONIX addressable algorithmic control panel for fire detection and fire alarm, certified according to EN 54-2 and EN 54-4 with UL-EU marking.

Control panel with capacity to adapt optimally to small and medium-sized installations.

The ONIX control panel has a capacity of 1 or 2 loops, with 226 elements and 64 relays per loop (452 elements and 128 relays in total), allowing for maximum performance when using A50xxLD fire detectors, which have built-in sound and visual alarm notification.

They have 2 independent sounder outputs, 2 independent 24/30V auxiliary power supply connectors with programmable reset, functionality to configure points in sequential order in the loop, to assist in locating open loops, the possibility of configuring points with the Cofem Installer mobile application with Android and IOS operating systems, I-Link software (for PC configuration), etc.

Enables Cofem 360 remote functionality on demand, receiving notifications of alarms, faults, etc., from a mobile phone

with internet access, as well as checking the latest events or performing actions on the control panel.

The control panel can connect up to 15 network control panels (Lyon, Quartz, Zafir and C-Lyon models), as well as connecting to a fire alarm receiving centre, Modbus protocol for integration into SCADA or similar systems, and I-link online (software for monitoring with installation plans and real-time action).

As for the loop elements, it is fully compatible with the Lyon system, noting that the sensors, alarm call points, relay modules, masters and technical signal modules are self-identifiable, meaning that they can all be installed without the need for previous manual coding, greatly facilitating assembly and subsequent modifications to the installation.

The control panel is CE marked in accordance with standards EN 54-2 and EN 54-4 and certified with the globally recognised UL-EU quality mark, demonstrating a firm commitment to quality and its production system.

FEATURES

- Control panel with 1 or 2 loops.
- Loop capability 226 points.
- Capacity for 64 relays per loop and 128 in total.
- Allows A50xxLD detectors with visual and sound alarm notification.
- Search for loop points in sequential order according to their physical position on the cable.
- Programming of 99 zones.
- Registry with capacity of 6601 events.
- Relay configuration with activation of 1, 2 or 3 alarm detectors.
- Relay trigger auto-configuration function.
- 2 independent programmable sounder outputs.
- 2 auxiliary 30V output connectors with programmable reset.
- Alarm output as an unmonitored voltage-free relay.
- Fault output, delayed and monitored.
- Allows addressable acoustic and visual sounders to be connected to the loop.
- Evacuation push button.
- Backlit LCD display with 4 lines and 40 characters.
- It incorporates several languages by default (Spanish, English, French, Portuguese, etc.).
- Configurable via PC software, I-Link.
- Event management with facility drawings using PC software, I-Link online.
- Access to the panel keypad using a numeric code.
- Connection of up to 15 repeaters and/or 15 network control panels.
- Cofem 360, CRI and MODBUS functionality on demand.
- Dimensions: 363 x 331 x 96 mm (with cover).
- UL/EU certification according to Standard EN 54 Part 2 and EN 54 Part 4, and CE marking according to European Construction Products Regulation (EU) No. 2024/3110.

TECHNICAL FEATURES

Input voltage	110/230 Vac 50/60Hz	Maximum current per loop	500mA/24 at 24V/DC
Output voltage	24V nominal	Communications port	USB 2.0/1.1 type B and RS485
Max. consumption	70VA at 230 VAC	Environmental conditions	-10°C+50°C 20%-95%RH
Battery charger	Yes	Dimensions	368x336x96mm (with cover)
Devices per loop	226	Weight (without batteries)	4,5kg
Battery fuse	4A	Standard	EN 54 part 2 and 4
IP protection	IP30	Sounder fuse S1	0,75A
Output fuse 30V	0,5A	Sounder fuse S2	0,5A



QUARTZ

ADDRESSABLE ALGORITHMIC CONTROL PANEL

Central algorítmica direccionable QUARTZ para detección y alarma de incendios, certificada según EN 54-2 y EN 54-4 con marcado UL-EU

Control panel with capacity to adapt optimally to small and medium-sized installations.

The QUARTZ control panel has a capacity of 1 or 2 loops, with 99 elements and 16 relays per loop (198 elements and 32 relays in total).

They have 2 independent sounder outputs, 2 independent 24/30V auxiliary power supply connectors with programmable reset, functionality to configure points in sequential order in the loop, to assist in locating open loops, the possibility of configuring points with the Cofem Installer mobile application with Android and IOS operating systems, I-Link software (for PC configuration), etc.

Enables Cofem 360 remote functionality on demand, receiving notifications of alarms, faults, etc., from a mobile phone with internet access, as well as checking the latest events or

performing actions on the control panel.

The control panel can connect up to 15 network control panels (Lyon, Quartz, Zafir and C-Lyon models), as well as connecting to a fire alarm receiving centre, Modbus protocol for integration into SCADA or similar systems, and I-link online (software for monitoring with installation plans and real-time action).

As for the loop elements, it is fully compatible with the Lyon system, noting that the sensors, alarm call points, relay modules, masters and technical signal modules are self-identifiable, meaning that they can all be installed without the need for previous manual coding, greatly facilitating assembly and subsequent modifications to the installation.

The control panel is CE marked in accordance with standards EN 54-2 and EN 54-4 and certified with the globally recognised UL-EU quality mark, demonstrating a firm commitment to quality and its production system.

FEATURES

- Control panel with 1 or 2 loops.
- Loop capability 99 points.
- Capacity for 64 relays per loop and 128 in total.
- Allows A50xxLD detectors with visual and sound alarm notification.
- Search for loop points in sequential order according to their physical position on the cable.
- Programming of 99 zones.
- Registry with capacity of 6601 events.
- Relay configuration with activation of 1, 2 or 3 alarm detectors.
- Relay trigger auto-configuration function.
- 22 independent programmable sounder outputs.
- 2 auxiliary 30V output connectors with programmable reset.
- Alarm output as an unmonitored voltage-free relay.
- Fault output, delayed and monitored.
- Allows addressable acoustic and visual sounders to be connected to the loop.
- Evacuation push button.
- Backlit LCD display with 4 lines and 40 characters.
- It incorporates several languages by default (Spanish, English, French, Portuguese, etc.).
- Configurable via PC software, I-Link.
- Event management with facility drawings using PC software, I-Link online.
- Access to the panel keypad using a numeric code.
- Connection of up to 15 repeaters and/or 15 network control panels.
- Cofem 360, CRI and MODBUS functionality on demand.
- Dimensions: 363 x 331 x 96 mm (with cover).
- UL/EU certification according to Standard EN 54 Part 2 and EN 54 Part 4, and CE marking according to European Construction Products Regulation (EU) No. 2024/3110.

TECHNICAL FEATURES

Input voltage	110/230 Vac 50/60Hz	Maximum current per loop	250mA/24 at 24V/DC
Output voltage	24V nominal	Communications port	USB 2.0/1.1 type B and RS485
Max. consumption	70VA at 230 VAC	Environmental conditions	-10°C+50°C 20%-95%RH
Battery charger	Yes	Dimensions	368x336x96mm (with cover)
Devices per loop	99	Weight (without batteries)	4,5kg
Battery fuse	4A	Standard	EN 54 part 2 and 4
IP protection	IP30	Sounder fuse S1	0,75A
Output fuse 30V	0,5A	Sounder fuse S2	0,5A



RUBÍ

ADDRESSABLE ALGORITHMIC CONTROL PANEL

RUBÍ addressable algorithmic control panel for fire detection and fire alarm, certified according to EN 54-2 and EN 54-4 with UL-EU marking.

Control panel with capacity to adapt optimally to small installations.

The RUBÍ control panel has a capacity of 1 loop, with 64 elements and 8 relays per loop.

They have 2 independent sounder outputs, 2 independent 24/30V auxiliary power supply connectors with programmable reset, functionality to configure points in sequential order in the loop, to assist in locating open loops, the possibility of configuring points with the Cofem Installer mobile application with Android and IOS operating systems, I-Link software (for PC configuration), etc.

Enables Cofem 360 remote functionality on demand, receiving notifications of alarms, faults, etc., from a mobile phone with internet access, as well as checking the latest events or performing actions on the control panel.

As for the loop elements, it is fully compatible with the Lyon system, noting that the sensors, alarm call points, relay modules, masters and technical signal modules are self-identifiable, meaning that they can all be installed without the need for previous manual coding, greatly facilitating assembly and subsequent modifications to the installation.

The control panel is CE marked in accordance with standards EN 54-2 and EN 54-4 and certified with the globally recognised UL-EU quality mark, demonstrating a firm commitment to quality and its production system.

FEATURES

- Control panel with 1 loop.
- Loop capability 64 points.
- Capacity for 8 relays per loop.
- Allows A50xxLD detectors with visual and sound alarm notification.
- Search for loop points in sequential order according to their physical position on the cable.
- Programming of 16 zones.
- Registry with capacity of 6601 events.
- Relay configuration with activation of 1, 2 or 3 alarm detectors.
- Relay trigger auto-configuration function.
- 2 independent programmable sounder outputs.
- 2 auxiliary 30V output connectors with programmable reset.
- Alarm output as an unmonitored voltage-free relay.
- Fault output, delayed and monitored.
- Allows addressable acoustic and visual sounders to be connected to the loop.
- Evacuation push button.
- Backlit LCD display with 4 lines and 40 characters.
- It incorporates several languages by default (Spanish, English, French, Portuguese, etc.).
- Configurable via PC software, I-Link.
- Access to the panel keypad using a numeric code.
- Cofem 360 functionality on demand.
- Dimensions: 363 x 331 x 96 mm (with cover).
- UL/EU certification according to Standard EN 54 Part 2 and EN 54 Part 4, and CE marking according to European Construction Products Regulation (EU) No. 2024/3110.

TECHNICAL FEATURES

Input voltage	110/230 Vac 50/60Hz	Maximum current per loop	250mA/24Vdc
Output voltage	24V nominal	Communications port	USB 2.0/1.1 type B and RS485
Max. consumption	70VA at 230 VAC	Environmental conditions	-10°C+50°C 20%-95%RH
Battery charger	Yes	Dimensions	368x336x96mm (with cover)
Devices per loop	64	Weight (without batteries)	4,5kg
Battery fuse	4A	Standard	EN 54 part 2 and 4
IP protection	IP30	Sounder fuse S1	0,75A
Output fuse 30V	0,5A	Sounder fuse S2	0,5A



ZAFIR

ADDRESSABLE ALGORITHMIC CONTROL PANEL

Zafir addressable algorithmic control panel for fire detection and fire alarm, certified according to EN 54-2 and EN 54-4

The Zafir Algorithmic addressable Control Panel is EN 54-2 and EN 54-4 according to the European Regulation of Construction Products.

The new development of Zafir control panel, allow integration of all the functionality of an addressable algorithmic system in a reduced-dimension cabinet with capacity up to 452 detectors in 2 loops.

The control panel is totally compatible with the Lyon system, highlighting that loop elements (sensors, manual call points, relay modules, masters, analogue sounders and technical signal modules) have the property of being auto-identifiable, that is to say, all of them can be installed with no need for prior manual encoding, facilitating enormously the assembly and subsequent modifications to the installation.

FEATURES

- Control panel configurable with 1 or 2 loops.
- Loop capability 226 points.
- All the points are supervised by the control panel, except the loop isolator KABY.
- Capacity for 32 relays per loop and 64 in total.
- Can hold up to 99 zones per panel.
- Registry with capacity of 6601 events with date and time.
- Relay configuration with activation of 1, 2 or 3 alarm detectors.
- Relay activation auto-configuration function.
- Allows the configuration of visual and/or sound devices of the detector bases as loop powered relays.
- Delay of supervised sounder output programmable between 0 to 10 minutes, identified as S1.
- Alarm output as free voltage relay not supervised, identified as ALARM.
- Fault output, delayed and supervised, identified as FAULT.
- Allowed to connect addressable sounders in the loop.
- Evacuation push-button.
- Backlit LCD display with 4 lines and 40 characters.
- Incorporates multiple languages by default (Spanish, English, French, Portuguese, etc).
- Configurable with the I-Link software.
- Access to the control panel keyboard introducing a numeric code.
- Allows connection of up to 15 repeaters and/or 15 control panels in network.
- Cofem Remote (on specific request).
- CRI functionality on demand.
- Size: 368 x 336 x 96 mm (with cover).
- Certified according to EN-54-2 and EN 54-4 and CE mark according to the European Regulation of Construction Products (UE) N° 2024/3110.

TECHNICAL FEATURES

Input voltage	110/230 Vac 50/60Hz	Maximum current per loop	500mA/24 at 36V/DC
Output voltage	21V nominal	Communications port	USB 2.0/1.1 type B & RS485
Maximum consumption	70VA at 230 VAC	Environmental conditions	-10°C+50°C 20%-95%RH
Batteries charger	Yes	Dimensions	368x336x96mm (with cover)
Devices per loop	226	Weight (without batteries)	4,5kg
Batteries fuse	4A	Standard	EN 54 parts 2 & 4
IP protection	IP30	S1 sounder fuse	1,85A autoreset
		30V output fuse	0,75A autoreset



COMPACT LYON

ADDRESSABLE ALGORITHMIC CONTROL PANEL

Compact Lyon addressable algorithmic control panel for fire detection and fire alarm, certified according to EN 54-2 and EN 54-4

The algorithmic addressable Control Panel Compact Lyon is EN 54-2 and EN 54-4 standard certified according to the latest CE Directives/Regulation.

The Compact Lyon panel does the same functions that Lyon Remote Control Panel, being fully compatible with it from the point of view of installation (cabling, analogue detectors, manual call points, modules and analogue sounders, etc.).

It is particularly interesting in medium-size installations, traditionally designed for conventional systems, allowing using an addressable system with all its functionality and advantage.

In case the installation should be extended, the Compact Lyon Control Panel has the control panels network function, whereby control panels can be connected together, also showing the information of the control panels connected to a repeater, besides allows an additional functionality of operation.

FEATURES

- Control panel configurable with 1 or 2 loops.
- Loop capability 99 points.
- All the points are supervised by the control panel, except the loop isolator KABY.
- Capacity up to 16 relays per loop, 32 totally.
- Can hold up to 99 zones per panel.
- Registry with capacity of 6601 events with date and time.
- Relay configuration with activation of 1, 2 or 3 alarm detectors.
- Relay activation auto-configuration function.
- Allows the configuration of visual and/or sound devices of the detector bases as loop powered relays.
- Delay of supervised sounder output programmable between 0 to 10 minutes, identified as S1.
- Alarm output as free voltage relay not supervised, identified as ALARM.
- Fault output, delayed and supervised, identified as FAULT.
- Allowed to connect addressable sounders in the loop.
- Evacuation push-button.
- Backlit LCD display with 4 lines and 40 characters.
- Incorporates multiple languages by default (Spanish, English, French, Portuguese, etc).
- Configurable with the I-Link software.
- Access to the control panel keyboard introducing a numeric code.
- Allows connection of up to 15 repeaters and/or 15 control panels in network.
- Cofem Remote (on specific request).
- CRI functionality on demand.
- Size: 368 x 336 x 96 mm (with cover).
- Certified according to EN 54-2 and EN 54-4 and EN 54-4 and CE mark according to the European Regulation of Construction Products (UE) N° 2024/3110.

TECHNICAL FEATURES

Input voltage	110/230 Vac 50/60Hz	Maximum current per loop	250mA/24 at 36V/DC
Output voltage	21V nominal	Communications port	USB 2.0/1.1 type B and RS485
Maximum consumption	70VA at 230 VAC	Environmental conditions	-10°C+50°C 20%-95%RH
Batteries charger	Yes	Dimensions	368x336x96mm (with cover)
Devices per loop	99	Weight (without batteries)	4,5kg
Batteries fuse	4A	Standard	EN 54 parts 2 and 4
IP protection	IP30	S1 sounder fuse	1,85A autoreset
		30V sounder output	0,75A autoreset

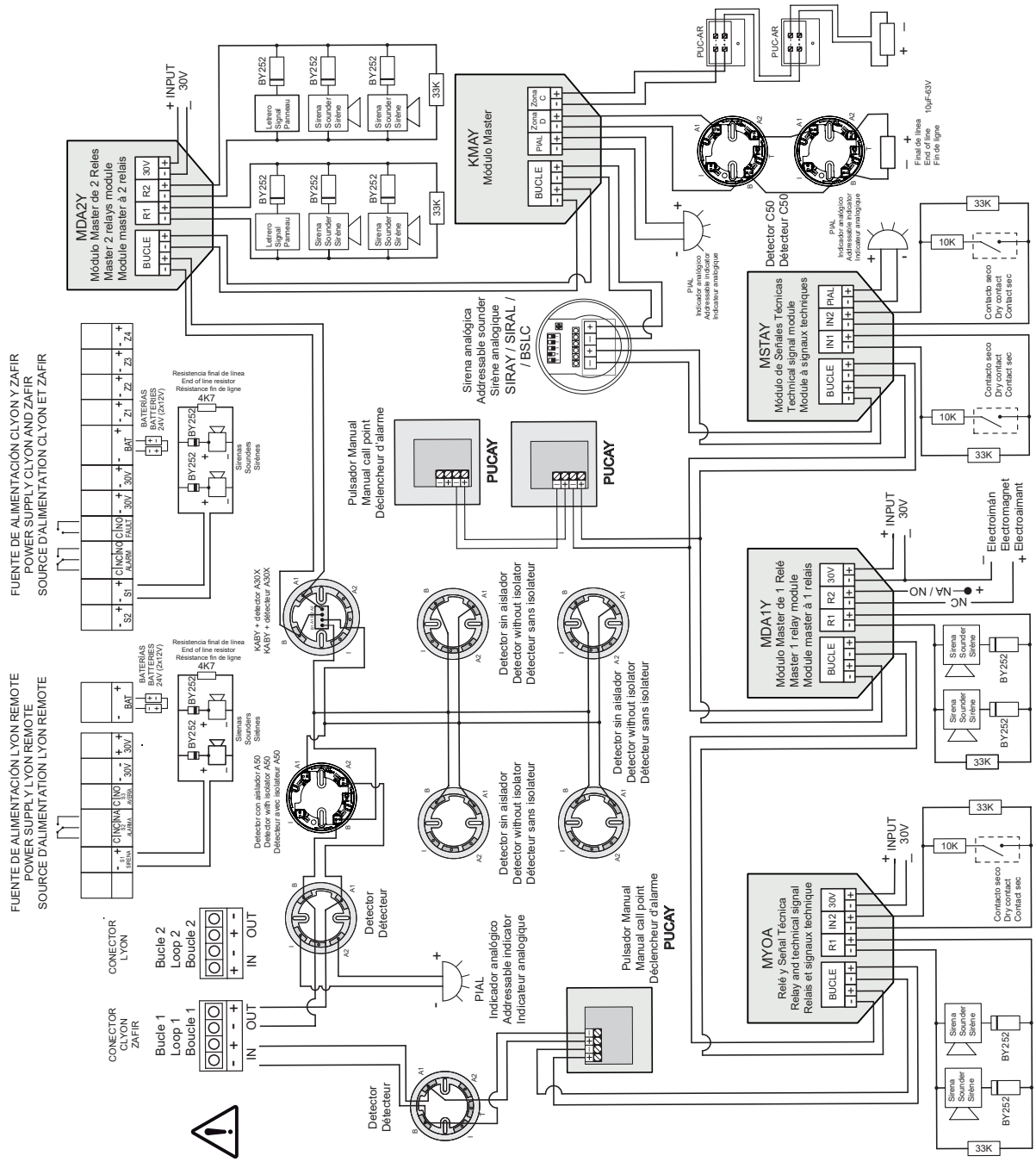

NOTE: Diagram indicates the installation of diodes in sounders. If these sounders have diode incorporated, it is not necessary to add it.

General wiring diagram Lyon Remote, Zafir y C-Lyon



I-LINK

MANAGEMENT SOFTWARE

Remote management software for fire detection system

I-LINK is a configuration and monitoring software for the Cofem algorithmic-addressable control panels. The I-LINK software is designed to perform two functions:

Configuration of the control panel:

With the software (in its basic version), the system's operating parameters can be configured by following a set of simple steps: the general activation parameters of the control panel, the definition of the points, the activation of the relays and the definition of the area listings and activation listings.

All this with functions that assist the user in simplifying the data entry procedures, such as the use of the Cofem Installer app (for smartphone and tablets), the display of the configuration settings in tree format, the possibility of copying and moving loops, of modifying the information directly on the tables of points, relays, etc.

Moreover, I-LINK allows for configuring the installation's video cameras and subsequently associating them in the extended version (ONLINE) to the detection elements.

ONLINE:

With the extended version of the software, I-LINK allows for ONLINE (real time) connection to the fire detection and alarm control panel, allowing the real-time display of the events, and

also allowing for action to be taken (monitoring, cancelling, starting up, activating evacuation, etc.).

For an improved display, the installations blueprints can be entered in several formats (including Autocad) and the different detection elements can be placed on these blueprints. When an event occurs, the appropriate blueprint is opened, focusing on the event, enabling the user to zoom in, switch blueprints, see the sequence of events, etc.

The installation's cameras can also be placed on the blueprints to relate them to the detection elements. Thus, when an event occurs, the related camera will be opened making it possible to view what is going on in that area of the installation. Also, at any time, you can click on any camera and view its images. On configuring the cameras, there is also the possibility of activating an image manager that will give us a warning in I-LINK ONLINE of the possible identification of fire.

By registering the installation in the Cofem Guard app (for smartphone, tablets or emails), I-LINK ONLINE will also send information of the events from the fire detection and alarm system to 5 users who will receive it in real time, depending on the connectivity/reception of these devices.

FEATURES

Basic Version (for programming the control panel):

- Allows for easy programming of the control panel from a PC.
- Allows for simple management of the configurations of all the Lyon Remote, Zafir and Compact Lyon installations.
- Loads the information on the installation's points from the Cofem Installer app.
- Configuration of the installation's video cameras.

Extended Version (for ONLINE management):

- Allows for ONLINE management of the control panel, offering many control possibilities.
- Displaying events on the installation's blueprints.
- Displaying of the video cameras of the fire detection events associated to the installation.
- Using RS232/485 converters, it allows for distances of up to 1200 m between the PC and the control panel.
- Allows for using wiring and the TCP/IP protocol in the installation.
- Possibility of managing up to 35 control panels simultaneously in a single installation.

NOTE: The functions offered in the product will depend on its version.

There are 4 software licences: ILINKLRM, for Lyon Remote control panels, ILINKZFR, for Zafir control panels, ILINKCTL, for Compact Lyon control panels, and ILINKONLINE, for use in any Cofem addressable control panel.

Lyon Remote connection diagram

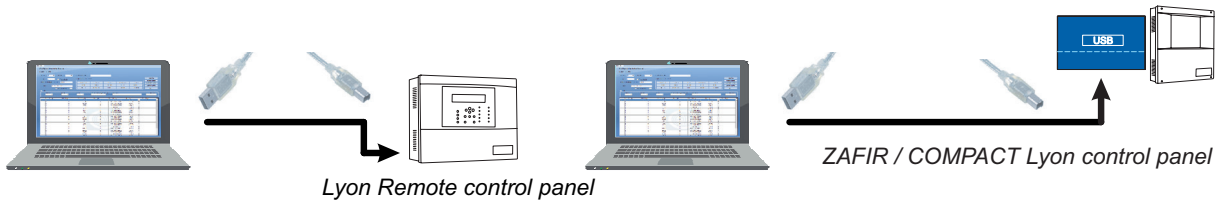

Connection 1 for control panel by RS485 or TCP/IP protocol (extended version)

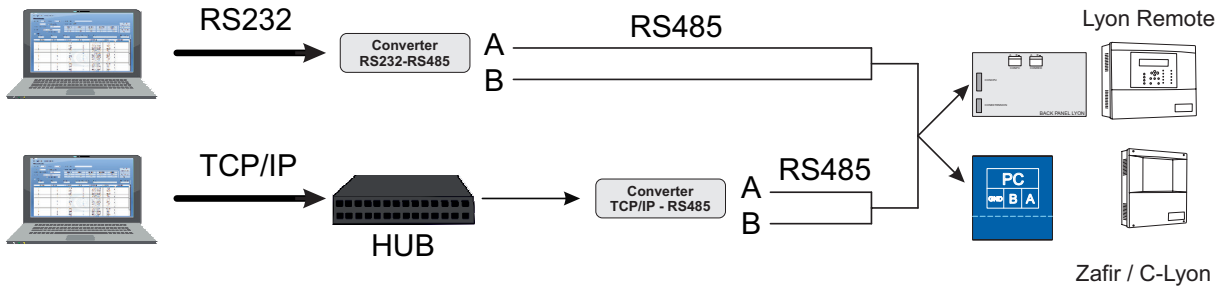

Example of connection network and with I-link

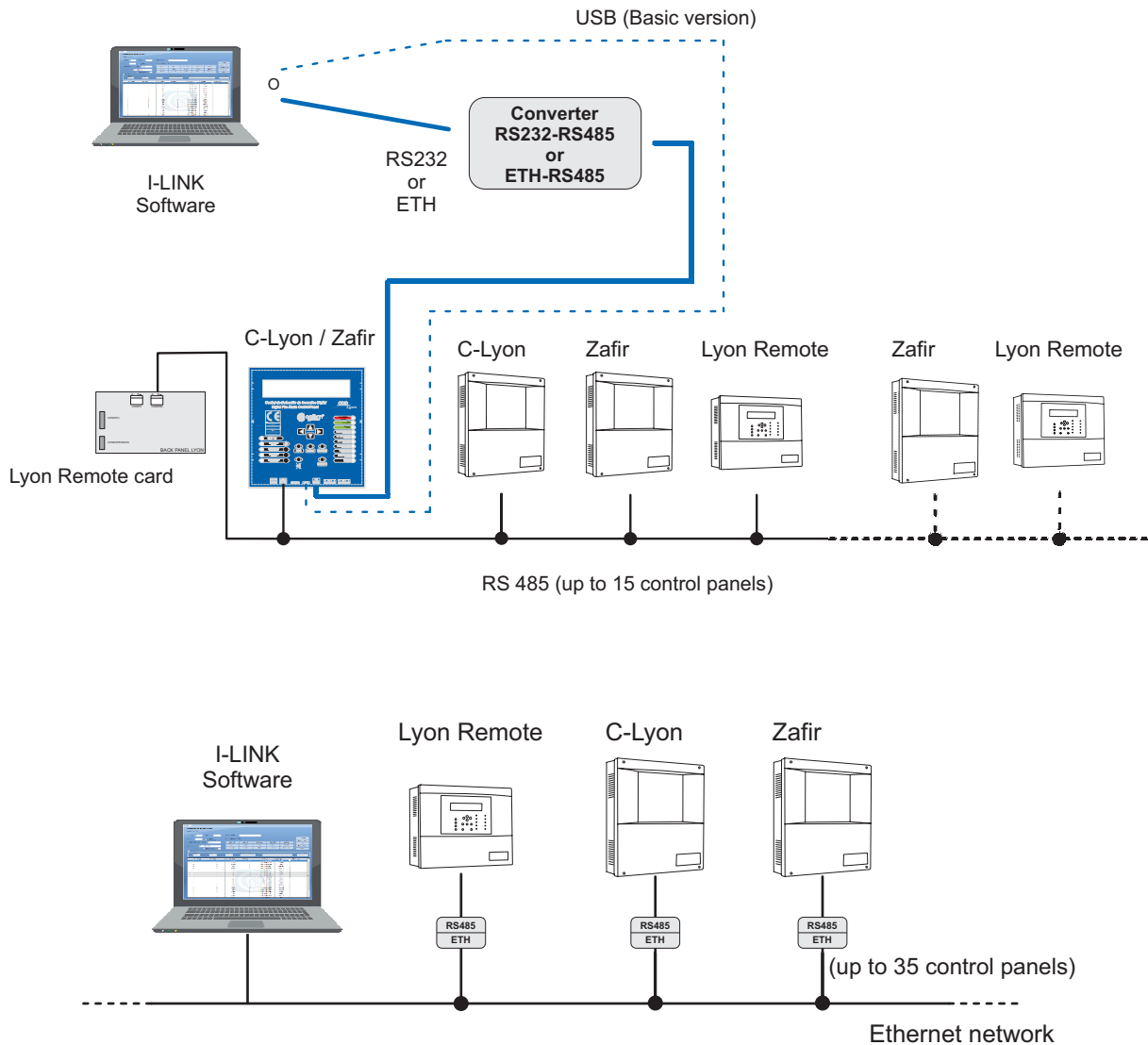



COFEM INSTALLER

ANDROID APP'S

Android application for setup configuration

Effortless installation, thus preventing errors and saving time

Following Cofem's philosophy based on the simplicity and reliability of its systems, the "COFEM Installers" app has been created, with the purpose of gathering the installation data required for the quick and easy configuration of the algorithmic addressable fire detection and alarm control panels, in three steps:

- 1- Open the application.
- 2- Create a new installation.
- 3- Scan the QR codes of the components (detectors, call points, etc.)

With this application you can carry all the information around with you without needing to make notes on pieces of paper, also avoiding any possible reading and writing errors. The information on the installations can also be sent or received by any means available on the phone/tablet to configure the installation's settings with the EasyCoNET / I-Link programme.

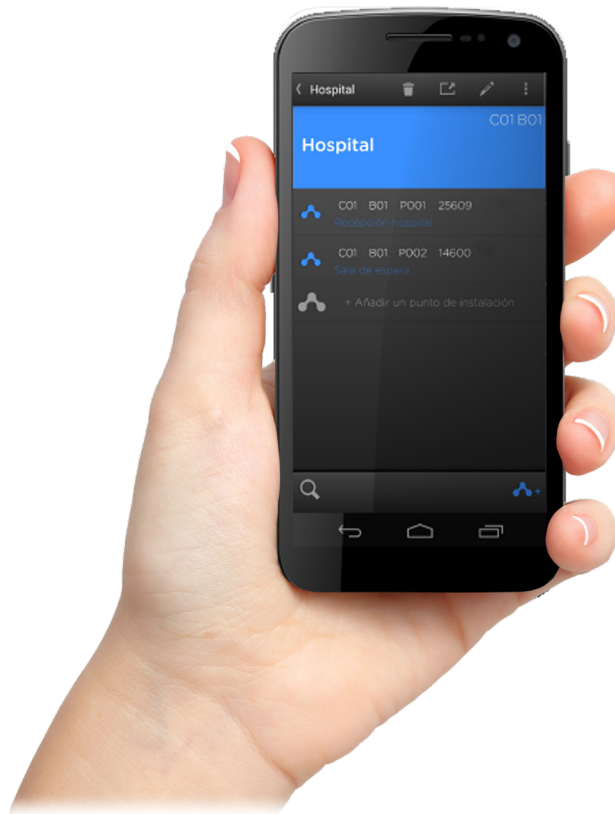



ZYR

ALGORITHMIC REPEATER CONTROL PANEL

Repeater control panel for the algorithmic detection system

The LYON REMOTE / ZAFIR / COMPACT Lyon control panel allows to connect up to 15 repeaters, using a 4 wires of 1,5 mm² connection (two for supply and two for communication for RS485 line). The two wires of the RS485 line will be connected from the control panel to the corresponding repeaters. The repeater wiring is realized like the figure attached.

From 30 V output of the control panel power supply is allowed up to 3 repeaters. For C-Lyon and Zafir control panels is allowed supply 1 repeater. The rest of repeaters should be connected from the 30 V output of an external power supply.

The wiring of repeaters, communication and power wires, will be realized with twisted and shielded halogen-free of 2x1,5 mm² wire, maximum length up to 1200 m.

In the end of the line should be connected a 120 Ω resistance, in the back panel of the last repeater.

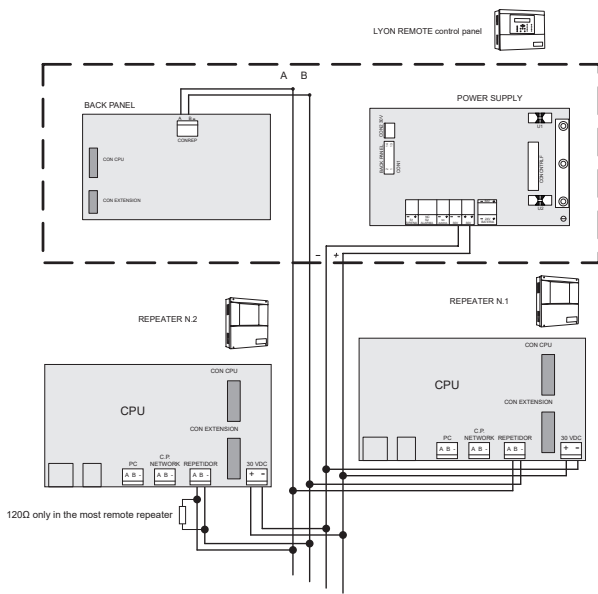

Lyon Remote control panel connection diagram

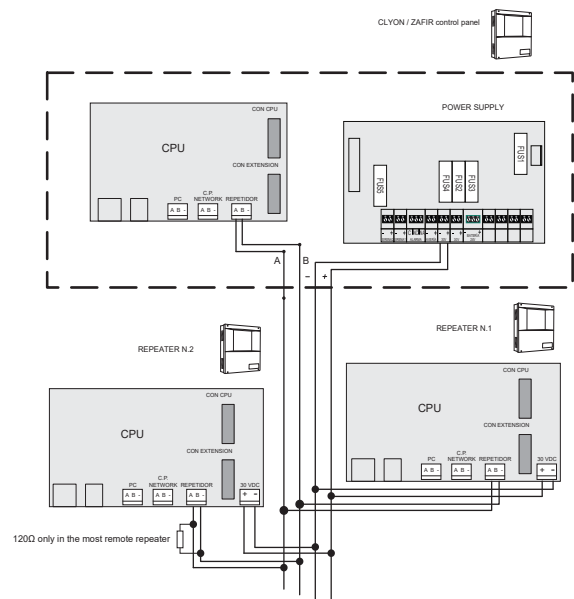

Zafir and Compact Lyon control panel connection diagram

TECHNICAL FEATURES			
Supply	30V	Dimensions	283x240x35mm
Standby consumption	150mA	Weight	2,4kg
Humidity	20 - 95% RH	IP protection	IP30
Temperature	-10°C - +50°C		

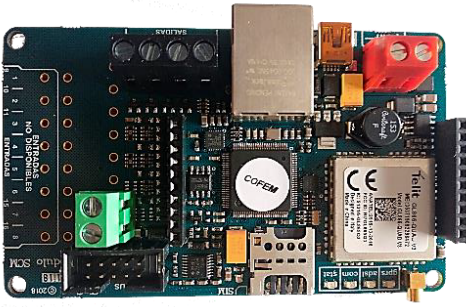

MCCRA

CONNECTION MODULE WITH CRI

Addressable module for connection with fire alarm control panel

Addressable module for connecting with alarm receiving center.

EN 54-21 certified card that allows connection of the C-Lyon, Zafir or Lyon addressable control panel with an Alarm Receiving Center (ARC).

The following factory options are available including the control panel, its special communication software with the MCCRA card and the MCCRA card.

- CLYON01BCRI
- CLYON02BCRI

- ZAFRI01BCRI
- ZAFIR02BCRI

- LYONRM01CRI
- LYONRM02CRI
- LYONRM03CRI
- LYONRM04CRI

* Ask for configurations with a higher number of loops.

In the case of spare parts or the need to add this ARC connection functionality to an already installed addressable control panels, the MCCRA Reference includes the card and the control panel communication software update with this card (in versions compatible with this functionality).

FEATURES

- Certified EN 54-21
- Communication with ContactID protocol.
- GPRS and ethernet connection (selectable).
- Notification to the ARC of selected and scheduled events.
- User notification via SMS, e-mail or customised mobile application.
- Software programming on PC via PC port or remote connection.
- Remote access and control of control panel status.



A50SHCOI

ADDRESSABLE MULTISENSOR



Addressable multisensor with isolator certified EN 54-5, EN 54-7 and EN 54-17

The A50 family of detectors are based on a new refined aesthetic that integrates the latest electronic technology with new, more efficient detection algorithms and a three-dimensional design that makes it more robust against environmental dirt.

The A50 family allows multiple combinations between smoke and heat detection, CO sensor and short-circuit isolator with UL certification.

The A50SHCOI model is a multi-sensor detector that has a short-circuit isolator and three different types of sensors: An smoke sensor, a heat sensor and a Carbon Monoxide (CO) sensor.

The use of the CO sensor is very valuable for the early detection of some types of fire, since the production of this gas is very common, especially in the initial phases of a fire. Its integration with the smoke sensor results in a compact detector that is very robust against false alarms.

To complete its features, a heat sensor with thermovelocimetric response is incorporated, reaching alarm status with a static temperature of 60°C in the case of slow fire developments.

FEATURES

- Smoke, Heat and CO sensor.
- With short circuit isolator.
- Low profile, total height less than 55 mm (including low base).
- Also available with high base for 20 mm tube.
- Possibility of connection to a remote action indicator.
- Easy connection.
- Bi-colour red and yellow LED.
- Indication, by means of the red LED, of the communication with the control panel (single flashing), as well as of the alarm status (LED on).
- Indication, by means of the yellow led (single flash), of the activation of the short-circuit isolator or the lack of communication with the control panel.
- Signalling of the dirty state of the sensor on the control panel display (the sensor allows to differentiate between rapid signal increases due to alarm and small, slow and sustained increases due to the accumulation of dust and dirt).
- Smoke and CO sensor processing algorithm that drastically reduces incidents due to false alarms.
- Easy installation of head and base, interchangeable throughout the A50 family, and made of white heat-resistant ABS.
- UL certified according to Standard EN 54-5 class A2R, EN 54-7 and EN 54 17 with CE marking according to the European Regulation on Construction Products (EU) N° 2024/3110.

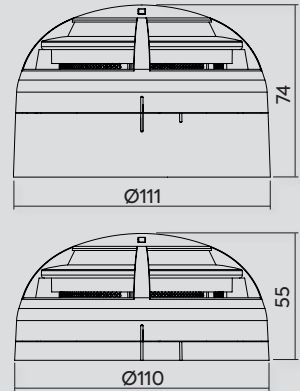

TECHNICAL FEATURES

Power supply	24 - 35V	Humidity	20 - 95%RH
Standby current	300µA	Application temperature	-10°C - +50°C
Alarm current	Red light	Sensitivity	According to EN 54-5 / EN 54-7 A2R
Activation signal	Yes	IP protection	IP20
Remote indicator output	Yes	Life span	10 years
Coverage area	104m² (subject to local regulation)	Installation height	15m (subject to local regulation)



A50SH

ADDRESSABLE SMOKE AND HEAT SENSOR



Addressable heat sensor certified EN 54-5 y EN 54-7

The A50 family of detectors are based on a new refined aesthetic that integrates the latest electronic technology with new, more efficient detection algorithms and a three-dimensional design that makes it more robust against environmental dirt.

The A50 family allows multiple combinations between smoke and heat detection, CO sensor and short-circuit isolator with UL certification.

The A50SH model is a detector that has two different types of sensors: An smoke sensor and heat sensor.

The smoke sensor is specially designed to detect the presence of combustion aerosols in a three-dimensional design that makes it more robust against dirt.

Regarding heat sensor, it allows the thermovelocimetric response of the detector, reaching the alarm status with a static temperature of 60°C in the case of slow fire developments.

FEATURES

- Smoke and heat sensor.
- Low profile, total height less than 55 mm (including low base).
- Also available with high base for 20 mm tube.
- Possibility of connection to a remote action indicator.
- Easy connection, without polarity).
- Bi-colour red and yellow LED.
- Indication, by means of the red LED, of the communication with the control panel (single flashing), as well as of the alarm status (LED on).
- Indication, by means of the yellow led (single flash), of the activation of the short-circuit isolator or the lack of communication with the control panel.
- Signalling of the dirty state of the sensor on the control panel display (the sensor allows to differentiate between rapid signal increases due to alarm and small, slow and sustained increases due to the accumulation of dust and dirt).
- Easy installation of head and base, interchangeable throughout the A50 family, and made of white heat-resistant ABS.
- UL certified according to Standard EN 54-5 class A2R and EN 54-7 with CE marking according to the European Regulation on Construction Products (EU) N° 2024/3110.

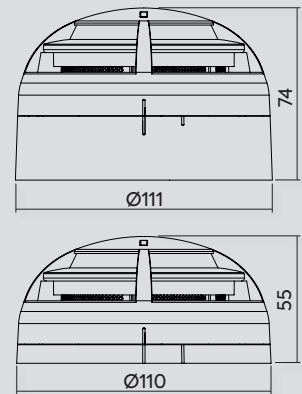

TECHNICAL FEATURES

Power supply	24 - 35V	Humidity	20 - 95%RH
Standby current	200µA	Application temperature	-10°C - +50°C
Alarm current	2mA	Storage temperature	-10°C - +55°C
Activation signal	Red light	Sensitivity	EN 54-7/EN 54-5 category A2R
Remote indicator output	Yes	IP protection	IP20
Coverage area	104m ² (subject to local regulation)	Installation height	15m (subject to local regulation)



A50SHI

HEAT AND SMOKE SENSOR
WITH ISOLATOR



Addressable heat and smoke sensor with isolator certified EN 54-5, EN 54-7 and EN 54-17

The A50 family of detectors are based on a new refined aesthetic that integrates the latest electronic technology with new, more efficient detection algorithms and a three-dimensional design that makes it more robust against environmental dirt.

The A50 family allows multiple combinations between smoke and heat detection, CO sensor and short-circuit isolator with UL certification.

The A50SHI model is a detector that has two different types of sensors: An smoke sensor and heat sensor. The A50SHI model incorporates a short circuit isolator.

The smoke sensor is specially designed to detect the presence of combustion aerosols in a three-dimensional design that makes it more robust against dirt.

Regarding heat sensor, it allows the thermovelocimetric response of the detector, reaching the alarm status with a static temperature of 60°C in the case of slow fire developments.

FEATURES

- Smoke and heat sensor.
- Short-circuit isolator incorporated.
- Low profile, total height less than 55 mm (including low base).
- Also available with high base for 20 mm tube.
- Possibility of connection to a remote action indicator.
- Easy connection.
- Bi-colour red and yellow LED.
- Indication, by means of the red LED, of the communication with the control panel (single flashing), as well as of the alarm status (LED on).
- Indication, by means of the yellow led (single flash), of the activation of the short-circuit isolator or the lack of communication with the control panel.
- Signalling of the dirty state of the sensor on the control panel display (the sensor allows to differentiate between rapid signal increases due to alarm and small, slow and sustained increases due to the accumulation of dust and dirt).
- Easy installation of head and base, interchangeable throughout the A50 family, and made of white heat-resistant ABS.
- UL certified according to Standard EN 54-5 class A2R, EN 54-7 and EN 54-17 with CE marking according to the European Regulation on Construction Products (EU) N° 2024/3110.

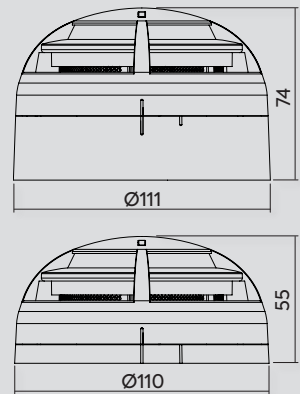

TECHNICAL FEATURES

Power supply	24 - 35V	Humidity	20 - 95%RH
Standby current	300µA	Application temperature	-10°C - +50°C
Alarm current	2mA	Storage temperature	-10°C - +55°C
Activation signal	Red light	Sensitivity	EN 54-7/EN 54-5 category A2R
Remote indicator output	Yes	IP protection	IP20
Coverage area	104m ² (subject to local regulation)	Installation height	15m (subject to local regulation)



A50S

SMOKE SENSOR



Addressable smoke sensor certified EN 54-7

The A50 family of detectors are based on a new refined aesthetic that integrates the latest electronic technology with new, more efficient detection algorithms and a three-dimensional design that makes it more robust against environmental dirt.

The A50 family allows multiple combinations between smoke and heat detection, CO sensor and short-circuit isolator with UL certification.

The A50S model is a detector that has a smoke sensor.

The smoke sensor is specially designed to detect the presence of combustion aerosols in a three-dimensional design that makes it more robust against dirt.

FEATURES

- Smoke sensor.
- Low profile, total height less than 42 mm (including low base).
- Also available with high base for 20 mm tube.
- Possibility of connection to a remote action indicator.
- Easy connection, without polarity.
- Bi-colour red and yellow LED.
- Indication, by means of the red LED, of the communication with the control panel (single flashing), as well as of the alarm status (LED on).
- Indication, by means of the yellow led (single flash), of the activation of the short-circuit isolator or the lack of communication with the control panel.
- Signalling of the dirty state of the sensor on the control panel display (the sensor allows to differentiate between rapid signal increases due to alarm and small, slow and sustained increases due to the accumulation of dust and dirt).
- Easy installation head and base, interchangeable throughout the A50 family, and made of white heat-resistant ABS.
- UL certificate according to EN 54-7 Standard with CE marking according to the European Regulation on Construction Products (EU) N° 2024/3110.

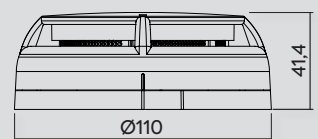
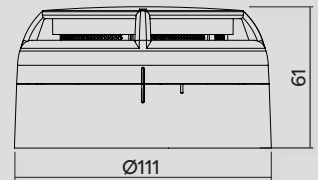

TECHNICAL FEATURES

Power supply	24 - 35V	Humidity	20 - 95%RH
Standby current	200µA	Application temperature	-10°C - +50°C
Alarm current	2mA	Storage temperature	-10°C - +55°C
Activation signal	Red light	Sensitivity	EN 54-7
Remote indicator output	Yes	IP protection	IP20
Coverage area	104m ² (subject to local regulation)	Installation height	15m (subject to local regulation)



A50SI

SMOKE SENSOR WITH ISOLATOR



Addressable smoke sensor with isolator certified EN 54-7 and EN 54-17

The A50 family of detectors are based on a new refined aesthetic that integrates the latest electronic technology with new, more efficient detection algorithms and a three-dimensional design that makes it more robust against environmental dirt.

The A50 family allows multiple combinations between smoke and heat detection, CO sensor and short-circuit isolator with UL certification.

The A50SI model is a detector that has a smoke sensor. The A50SI model incorporates a short-circuit isolator.

The smoke sensor is specially designed to detect the presence of combustion aerosols in a three-dimensional design that makes it more robust against dirt.

FEATURES

- Smoke sensor.
- Short-circuit isolator incorporated.
- Low profile, total height less than 42 mm (including low base).
- Also available with high base for 20 mm tube.
- Possibility of connection to a remote action indicator.
- Easy connection (and A50S without polarity).
- Bi-colour red and yellow LED.
- Indication, by means of the red LED, of the communication with the control panel (single flashing), as well as of the alarm status (LED on).
- Indication, by means of the yellow led (single flash), of the activation of the short-circuit isolator or the lack of communication with the control panel.
- Signalling of the dirty state of the sensor on the control panel display (the sensor allows to differentiate between rapid signal increases due to alarm and small, slow and sustained increases due to the accumulation of dust and dirt).
- Easy installation head and base, interchangeable throughout the A50 family, and made of white heat-resistant ABS.
- UL certificate according to EN 54-7 and EN 54-17 Standard with CE marking according to the European Regulation on Construction Products (EU) N° 2024/3110.

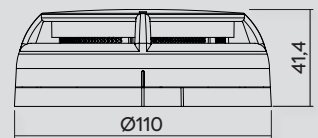
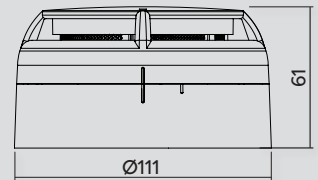

TECHNICAL FEATURES

Power supply	24 - 35V	Humidity	20 - 95%RH
Standby current	300µA	Application temperature	-10°C - +50°C
Alarm current	2mA	Storage temperature	-10°C - +55°C
Activation signal	Red light	Sensitivity	EN 54-7
Remote indicator output	Yes	IP protection	IP20
Coverage area	104m ² (subject to local regulation)	Installation height	15m (subject to local regulation)



A50H

ADDRESSABLE HEAT SENSOR



Addressable heat sensor certified EN 54-5

The A50 family of detectors are based on a new refined aesthetic that integrates the latest electronic technology with new, more efficient detection algorithms and a three-dimensional design that makes it more robust against environmental dirt.

The A50 family allows multiple combinations between smoke and heat detection, CO sensor and short-circuit isolator with UL certification.

The A50H model is a detector that has a heat sensor.

The heat sensor has thermovelocimetric behaviour, reaching alarm status with a static temperature of 60°C in the case of slow fire developments.

FEATURES

- Heat sensor.
- Low profile, total height less than 42 mm (including low base).
- Also available with high base for 20 mm tube.
- Possibility of connection to a remote action indicator.
- Easy connection (and A50S without polarity).
- Bi-colour red and yellow LED.
- Indication, by means of the red LED, of the communication with the control panel (single flashing), as well as of the alarm status (LED on).
- Indication, by means of the yellow led (single flash), of the activation of the short-circuit isolator or the lack of communication with the control panel.
- Easy installation of head and base, interchangeable throughout the A50 family, and made of white heat-resistant ABS.
- UL certificate according to Standard EN 54-5 class A2R with CE marking according to the European Regulation on Construction Products (EU) N° 2024/3110.

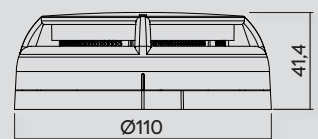
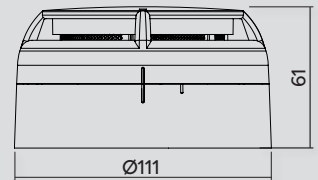

TECHNICAL FEATURES

Power supply	24 - 35V	Humidity	20 - 95%RH
Standby current	200µA	Application temperature	-10°C - +50°C
Alarm current	2mA	Storage temperature	-10°C - +55°C
Activation signal	Red light	Sensitivity	EN 54-5 category A2R
Remote indicator output	Yes	IP protection	IP20
Coverage area	52m ² (subject to local regulation)	Installation height	6m (subject to local regulation)



A50HI

ADDRESSABLE HEAT SENSOR WITH ISOLATOR



Addressable heat sensor with isolator certified EN 54-5

The A50 family of detectors are based on a new refined aesthetic that integrates the latest electronic technology with new, more efficient detection algorithms and a three-dimensional design that makes it more robust against environmental dirt.

The A50 family allows multiple combinations between smoke and heat detection, CO sensor and short-circuit isolator with UL certification.

The A50HI model is a detector that has a heat sensor. It also incorporates a short circuit isolator.

The heat sensor has thermovelocimetric behaviour, reaching alarm status with a static temperature of 60°C in the case of slow fire developments.

FEATURES

- Heat sensor.
- Short-circuit isolator incorporated.
- Low profile, total height less than 42 mm (including low base).
- Also available with high base for 20 mm tube.
- Possibility of connection to a remote action indicator.
- Easy connection (and A50S without polarity).
- Bi-colour red and yellow LED.
- Indication, by means of the red LED, of the communication with the control panel (single flashing), as well as of the alarm status (LED on).
- Indication, by means of the yellow led (single flash), of the activation of the short-circuit isolator or the lack of communication with the control panel.
- Easy installation of head and base, interchangeable throughout the A50 family, and made of white heat-resistant ABS.
- UL certificate according to Standard EN 54-5 class A2R and EN 54-17 with CE marking according to the European Regulation on Construction Products (EU) N° 2024/3110.

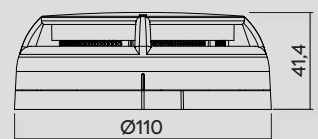
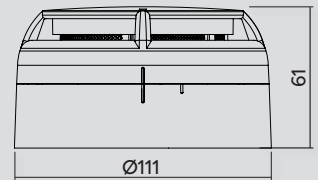

TECHNICAL FEATURES

Power supply	24 - 35V	Humidity	20 - 95%RH
Standby current	300µA	Application temperature	-10°C - +50°C
Alarm current	2mA	Storage temperature	-10°C - +55°C
Activation signal	Red light	Sensitivity	EN 54-5 category A2R
Remote indicator output	Yes	IP protection	IP20
Coverage area	52m ² (subject to local regulation)	Installation height	6m (subject to local regulation)



A30XHTCO

ADDRESSABLE MULTISENSOR

Addressable multisensor certified EN 54-7

Algorithmic addressable multisensor for fire detection.

The A30XHTCO has three different types of sensors: one optical smoke sensor, one heat sensor and one carbon monoxide sensor (CO).

The use of the CO sensor is very valuable for the early detection for some types of fire.

As well, the integration with the optical smoke detector inside its algorithm of dynamic processing, give us, as main results, a compact detector very robust facing the false alarms

For complete its benefits, the sensor also has a heat element sets it alarm status when temperature reaches 60°C.

FEATURES

- Low section, total height less than 53,4 mm (including the base).
- Available with high base for electrical conduit of 20 mm.
- Alarm with two red LED, which makes easier the identification from any direction (360°).
- Possibility to connect a remote action indicator.
- Easy connection, without polarity.
- A single flash of LED indicators shows communication with the control panel, and alarm status with LED on.
- Indication of contamination status of the sensor in the control panel display (the sensor discriminates between fast alarm signal and slow and sustained small increases due to the accumulation of dust and dirt).
- Dynamic processing algorithm that reduces drastically incidences due to false alarms.
- Detector and base with easy installation, interchangeable with the entire of range A30X, and manufactured in white heat-resistant ABS.
- According to EN 54-7 Standard, and CE mark according to the European Regulation of Construction Products (UE) N° 2024/3110.

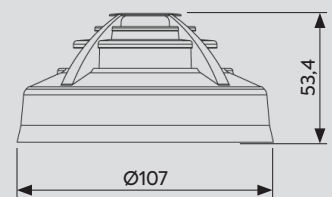
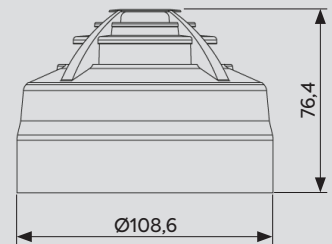

TECHNICAL FEATURES

Power supply	24 - 35V without polarity	Humidity	20 - 95%RH
Standby current	1mA	Temperature	-10°C - +50°C
Alarm current	5mA	Sensitivity	According to EN 54-7
Activation signal	Two red led (360° visibility)	IP protection	IP40
Remote indicator output	Yes	Life span	10 years
Coverage area	104m ² (subject to local regulation)	Installation height	15m (subject to local regulation)



A30XHA



A30XHAS

A30XHA A30XHAS

SMOKE SENSOR

Addressable smoke detector certified EN 54-7

Algorithmic addressable optical smoke sensor for fire detection.

The optical smoke sensor A30XHA / A30XHAS is based on the Tyndall effect (light refraction in a dark chamber) created in an optical chamber.

The variation of the electrical features of the chamber in the presence of combustion aerosols makes it suitable for smoke sensing.

The sensor A30XHA (optical-heat sensor) also has a static heat element that sets it into alarm status when temperature reaches 60°C.

FEATURES

- Low section, total height less than 53,4 mm (including the base).
- Available with high base for electrical conduit of 20 mm.
- Alarm with two red LED, which makes easier the identification from any direction (360°).
- Possibility to connect a remote action indicator.
- Easy connection, without polarity.
- A single flash of LED indicators shows communication with the control panel, and alarm status with LED on.
- Indication of contamination status of the sensor in the control panel display (the sensor discriminates between fast alarm signal and slow and sustained small increases due to the accumulation of dust and dirt).
- Detector and base with easy installation, interchangeable with the entire of range A30X, and manufactured in white heat-resistant ABS.
- According to EN 54-7 Standard, and CE mark according to the European Regulation of Construction Products (UE) N° 2024/3110.

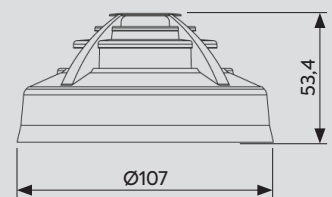
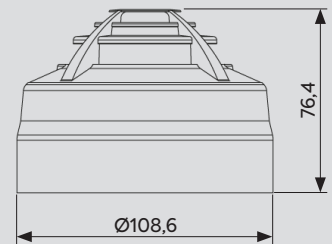

TECHNICAL FEATURES

Power supply	24 - 35V without polarity	Humidity	20 - 95%RH
Standby current	1mA	Temperature	-10°C - +50°C
Alarm current	5mA	Sensitivity	According to EN 54-7
Remote indicator output	Two red led (360° visibility)	IP protection A30XHA	IP20
Remote indicator output	Yes	IP protection A30XHAS	IP40
Coverage area	104m ² (subject to local regulation)	Installation height	15m (subject to local regulation)



A30XTA

HEAT SENSOR

Addressable heat sensor certified EN 54-5

Algorithmic addressable heat sensor for fire detection.

The A30XTA sensor is based on the physical properties of a NTC. The variation of the electrical features of the NTC thermistor due to variation of room temperature makes it suitable for a heat sensor.

The A30XTA is capable of registering absolute temperatures (heat sensor) but also temperature rises (rise of heat rate sensor).

The heat rate function allows detect a fire in the first phases of its growth. If it is very slow, the sensor is activated when temperature reaches 60°C.

FEATURES

- Low section, total height less than 45 mm (including the base).
- Available with high base for electrical conduit of 20 mm.
- Alarm with two red LED, which makes easier the identification from any direction (360°).
- Possibility to connect a remote action indicator.
- Easy connection, without polarity.
- A single flash of LED indicators shows communication with the control panel, and alarm status with LED on.
- Detector and base with easy installation, interchangeable with the entire of range A30X, and manufactured in white heat-resistant ABS.
- According to EN 54 part 5 class A2R (sensors with heat rise function), and CE mark according to the European Regulation of Construction Products (UE) N° 2024/3110.

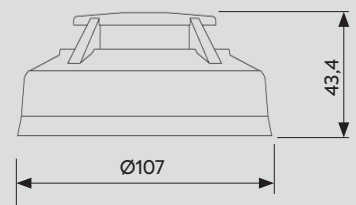
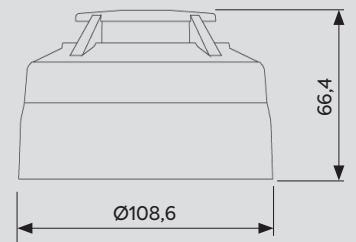

TECHNICAL FEATURES

Power supply	24 - 35V without polarity	Humidity	20 - 95%RH
Standby current	1mA	Temperature	-10°C - +50°C
Alarm current	5mA	Sensitivity	According EN 54-5 Class A2R
Activation signal	Two red led (360° visibility)	IP protection	IP20
Remote indicator output	Yes		
Coverage area	52m ² (subject to local regulation)	Installation height	6m (subject to local regulation)



PUCAY

RESETTABLE MANUAL CALL POINT

Addressable resettable alarm call point certified EN 54-11

Resettable Manual Call Point (with short-circuit isolator) for algorithmic addressable detection systems.

side of the activation face. A single flash shows communication with the control panel.

It has a LED that lights up when the call point is manually triggered (alarm), as well as showing a yellow tab on the lower

It is easy to reset through activation of the yellow button sited in the front face by means of a screwdriver.

FEATURES

- Easily resettable call point by pushing yellow button on the front side.
- Transparent protector cover to avoid accidental false alarms.
- Self-identified element in the fire detection algorithmic and addressable.
- Communication with the control panel is indicated by a single flash of the LED.
- Immediate visual recognition of alarm status by the permanent activation of the LED, and the trigger of the yellow tab on the lower side of the activation face.
- According to EN 54-11 Standard, and CE mark according to the European Regulation of Construction Products (UE) N° 2024/3110.

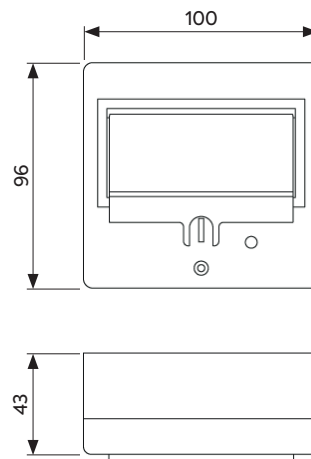
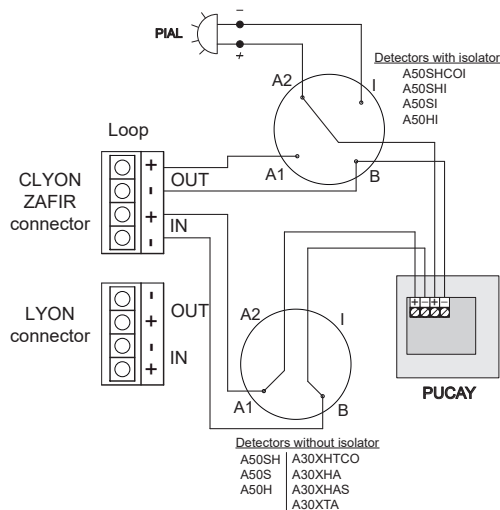

TECHNICAL FEATURES

Power supply	24 - 35V without polarity	Humidity	20 - 95%RH
Standby current	1mA	Temperature	-10°C - +50°C
Alarm current	5mA	Standard	EN 54-11
Activation signal	Red light	IP protection	IP50
Remote indicator output	No		



SIRENDL / SIRENDB



SIREND

SIREND SIRENDL SIRENDB

ALARM SOUNDER

Certified addressable alarm sounders

Certified addressable sounder and visual alarm device.

The SIREND sounder is an acoustic fire alarm notification device for buildings with EN 54-3, EN 54-17 certification and CE mark.

The SIRENDB sounder is an acoustic and visual fire alarm notification device for buildings with EN 54-3, EN 54-17 certification and CE mark.

The SIRENDL sounder is an acoustic and visual fire alarm notification device for buildings with EN 54-3, EN 54-17, CE mark and additionally EN 54-23 certification.

These sounders have a microprocessed addressable digital module (with short-circuit isolator) SIRAYC inside, which allows them to connect to the loop. The unit operates as a single relay, identifying itself and acting in the control panel as a SIRAY.

The sounder is made of heat-resistant red ABS.

The standard configuration of the sounder sound is shown in the following figure in accordance with standard EN 54-3 (acoustic device). The same figure shows the standard configuration of the light signal in accordance with standard EN 54-23 (SIRENDL visual alarm device).

It is possible to change the tone and light signal selection, but this operation affects the sounder's power consumption and, therefore, the device's point consumption. Power consumption can be calculated using the loop element capacity calculation software.

The internal wiring and positions of other microswitchs must not be modified from those selected by the manufacturer in these instructions.

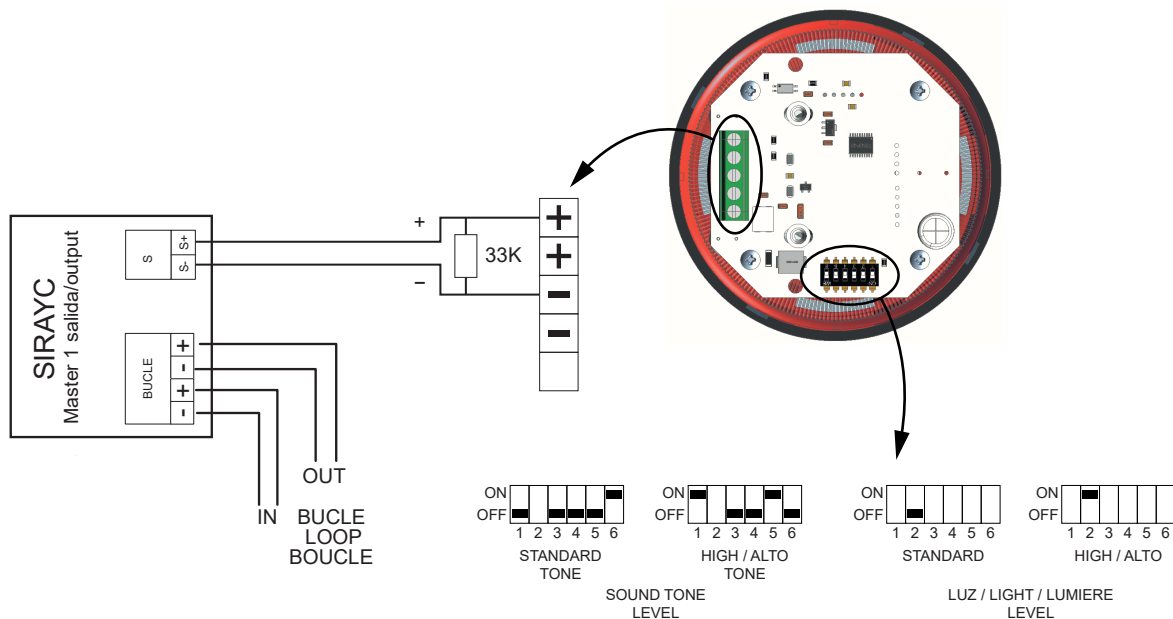

TECHNICAL FEATURES			
Power supply	24 - 35V with polarity	Standard	EN 54-3: SIREND, SIRENDB
Standby current	1mA		EN 54-23: SIRENDL
Alarm current	6 - 35mA	IP protection	IP65
Short-circuit isolator	Yes	Standard sound intensity	93 dB -1m Tone Sweep 1s 800-970Hz
Operative temperature	-10°C - +55°C	High sound intensity	105 dB -1m Tone Sweep 1s 2400-2850Hz
Dimensions	Ø98x78mm	Light intensity (SIRENDL)	W-2,4-2,6/W-3,2-6,8 0,5Hz



SIRAY / SIRAYL SIRAY+BSLC

ALARM SOUNDER

Certified addressable alarm sounders

The references SIRAY / SIRAYL / SIRAY + BSLC are made up of the following elements:

- SIRAY= Sounder + SIRAYC card
- SIRAYL= Sounder with light + SIRAYC card
- SIRAY+BSLC= Sounder + SIRAYC card + Base with light

SIRAYC card is a digital module microprocessed and addressable device (with short-circuit isolator) installed as another element inside the loop. The sounder is made of in ABS heat-resistant plastic red colour.

Is a module with a single programming function in terms of the timing and combination of sensors that trigger it. This sounder is configured as a relay acting as sounder.

The variant SIRAYL and SIRAY+BSLC additionally emit light signals, where in addition, the SIRAY+BSLC makes it according to EN 54-23 (visual alarm device). The fact that specifically these

sounders emitting light does not affect the programming of the control panel. For this reason, these devices are programmed in the control panel as if they were the reference SIRAY.

The standard configuration of the sound of the sounder is shown in the bottom figure according to EN 54-3 (acoustic device). The same figure shows the standard configuration of the light signal at the base of the sounder SIRAY+BSLC according to EN 54-23 (visual alarm device).

It is possible to change the tone and light signal selection, but this operation affects the power consumption of the sounder, and therefore, the consumption of the device points. It is possible to calculate the consumption with the calculation software of loop elements capacity.

Internal wiring and other microswitch positions must be unmodified selected by the manufacturer.

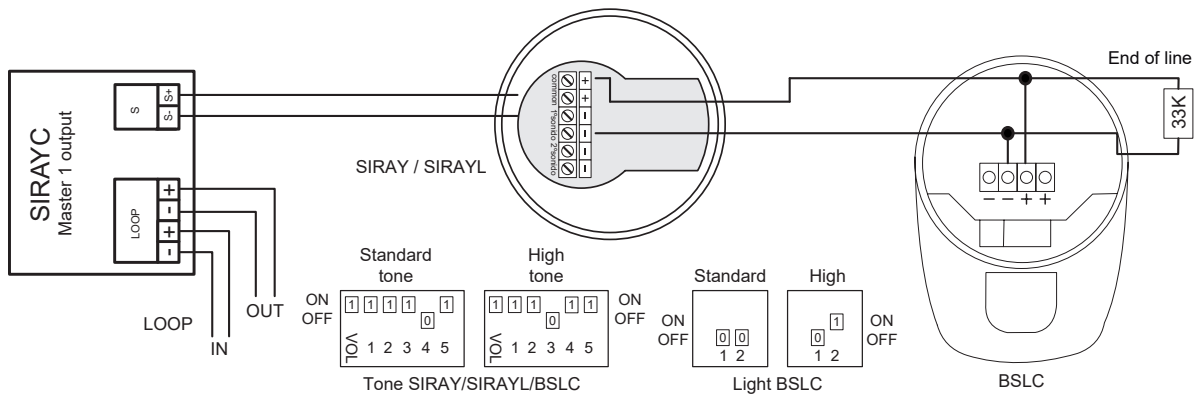

TECHNICAL FEATURES			
Power supply	24 - 35V with polarity		EN 54-3 / EN 54-23 (BSLC)
Standby current	1mA	Standard	SIRAYC: EN54-17 and EN 54-18
Alarm current	5 - 50mA	IP protection	IP65
Short-circuit isolator	Yes	Sound level	95 / 105dB - 1m (SIRAY / SIRAYL)
Operative temperature	-10°C - +55°C	Light level	w 2,4 - 2,3 / 7,5m (BSLC)
Dimensions	Ø95x91mm / Ø95x107mm (SIRAYL)		
	Ø95X95 (high) x 135mm (SIRAY+BSLC)		



PIAL

REMOTE INDICATOR

Remote action indicator for fire detection systems

Remote action indicator of fire detection system.

The PIAL allows showing alarm status of the fire detection system detectors.

Typical cases of use:

- Places where elements of the detection system are not visible, for example, inside false ceiling, in which the PIAL can be visibly situated on the lower part of the ceiling or near the wall.

- Reduced accessibility rooms or that is needed do a big inspection range for the identification of the element in alarm, for example in hotel rooms, where the PIAL can be situated above the door frame of each room, making very easy its identification.

Permanent activation of the red LED indicates alarm status.

It is an element easy to install, both for its electrical wiring and its fixation, furthermore, can be adapted to the conduit boxes and switchgear.

FEATURES

- Alarm status can be identified in any perpendicular direction at its installation.
- Easy connection, with polarity.
- Can be adapted to the conduit boxes and switchgear.
- The red light is produced by two LEDs, increasing reliability against failure of any of them.
- Manufactured in heat-resistant ABS. Base and lid are white, red viewer.

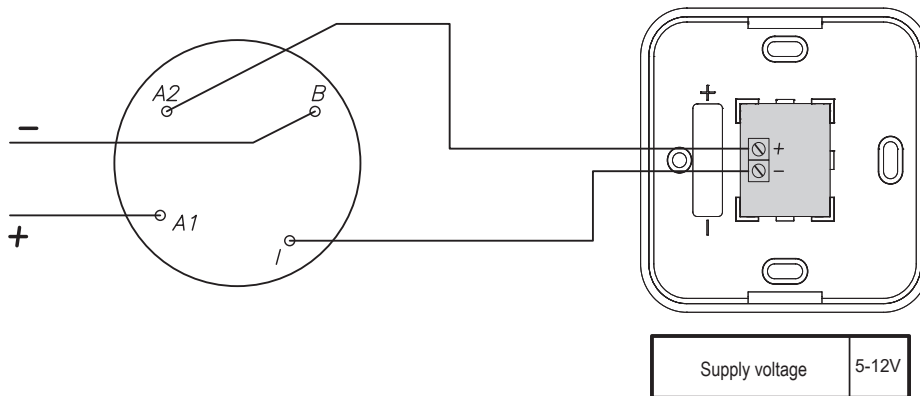

TECHNICAL FEATURES

Supply	5 - 12V/DC with polarity	Humidity	20 - 95%RH
Standby consumption	0mA	Temperature	-10°C - +50°C
Alarm consumption	5mA	IP protection	IP50
Activation signal	Red led		



K MAY

MODULE FOR CONVENTIONAL ELEMENTS

NEW

Module for conventional elements certified EN 54-18

Microprocessed algorithmic addressable loop device (with short-circuit isolator)

This is a device that allows connecting conventional detectors and/or manual call point inside an algorithmic addressable fire detection system, performing the interface function between the algorithmic addressable detection system and the conventional one.

In the "Zona C" terminal, a maximum of 10 conventional call points can be installed. In the "Zona D" terminal, it is allowed 20 temperature detectors (A50, A30X range) or 15 elements between conventional smoke detectors (A50, A30X range) and manual call points. Both terminals are monitored by an end of line capacitor, 10µF/63V. In this way, it is indicated an open line, crossed line, alarm detector or alarm manual call point status.

The red Led blinking indicates communication with the control panel, and if it remains lit it indicates the alarm status of a detector or a manual call point connected to this module.

This module has an output for activation of a remote indicator which will be activated when alarm status is reached. The Master Detection Module is a loop powered device.

The Master Detection Module is supplied in a rectangular, heat-resistant ABS box, to be mounted on surface or on DIN rail.

The module is certified according to EN 54-18 Standard, and CE mark according to the European Regulation of Construction Products (UE) N° 2024/3110.

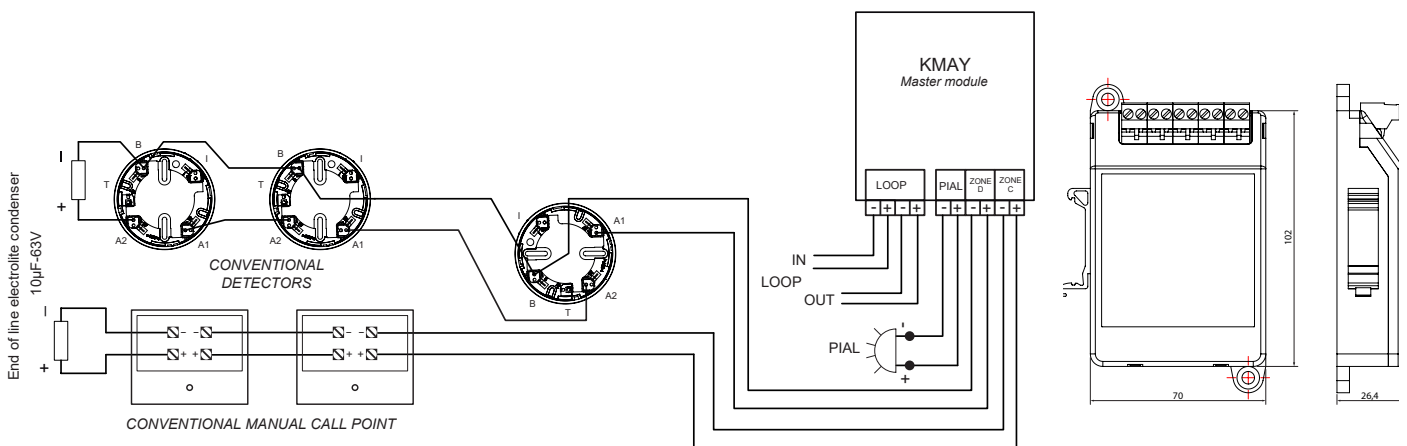

TECHNICAL FEATURES			
Module power supply	loop 24 - 35V with polarity	Humidity	20 - 95%RH
Standby current	1mA	Temperature	-10°C - +50°C
Short-circuit isolator	Yes	Dimensions (totals)	82,5x123x26,4mm
Zone voltage	20V with polarity	Standard	EN 54-18
Activation signal	Red light	IP protection	IP30
Remote indicator output	Yes		

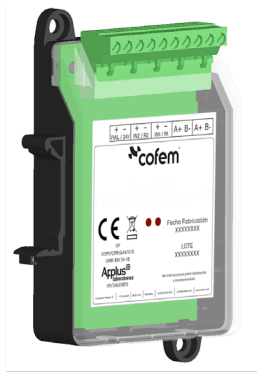

MSTAY

TECHNICAL SIGNALS MODULE

NEW

Technical signals module certified EN 54-18

Microprocessed algorithmic addressable loop device (with short-circuit isolator).

It has two inputs to distinguish between the open or close state of a dry contact connected in series with a 10 kΩ resistor. In quiescent condition, the contact has to be open, and in anomaly condition, the contact has to be closed.

In the first input (marked with IN1), the closed contact is detected as an ALARM condition. In the second input (marked with IN2), the closed contact is detected as FAULT warning condition. It is possible to associate both inputs having an alarm and fault conditions information.

In the quiescent condition, the device supervises the electrical connection through a 33 kΩ resistor, which allows indication of open electrical connection or short circuit status.

It is usually used to inform about the status of other detection systems associated to Cofem systems, like flow sensors in the case of sprinkler installations, end of stroke for fire-resistant doors, elevators, or level of deposits, etc.

The red Led blinking indicates communication with the control panel, and if it remains lit it indicates the alarm status. The lit green LED indicates activation of one or both inputs.

This device has an output for connection to a remote action indicator, which is activated when in case of alarm status. The technical signals module is a loop powered device.

The device is supplied in a rectangular, heat-resistant ABS box, to be mounted on surface or on DIN rail.

The module is certified according to EN 54-18 Standard, and CE mark according to the European Regulation of Construction Products (UE) N° 2024/3110.

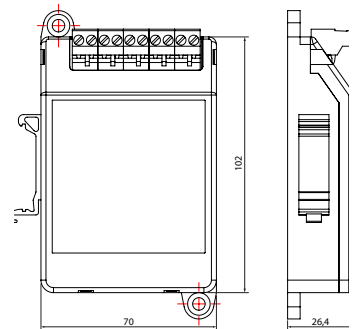
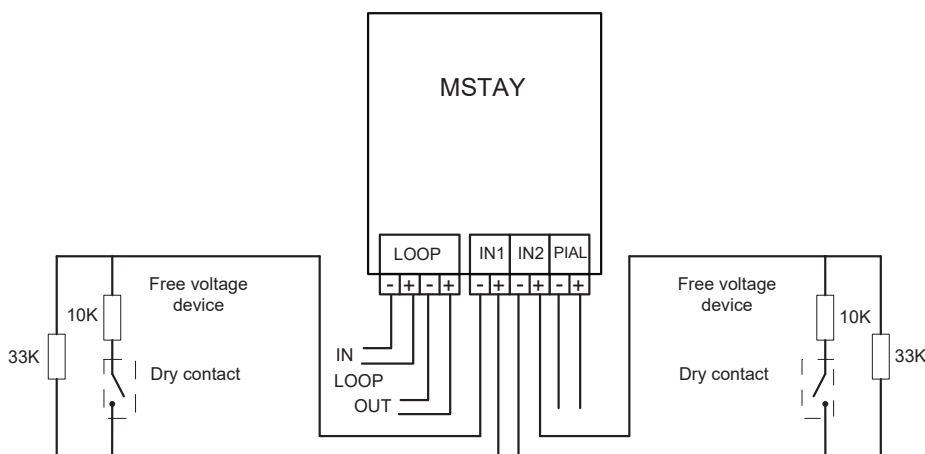

TECHNICAL FEATURES			
Module power supply	loop 24 - 35V with polarity	Communication/Alarm indicator	Red light
Standby current	1mA	Humidity	20 - 95%RH
Short-circuit isolator	Yes	Temperature	-10°C - +50°C
Supervision voltage	7V with reverse polarity	Dimensions (totals)	82,5x123x26,4mm
Remote indicator output	Green light	Standard	EN 54-18
Activation signal	Yes	IP protection	IP30

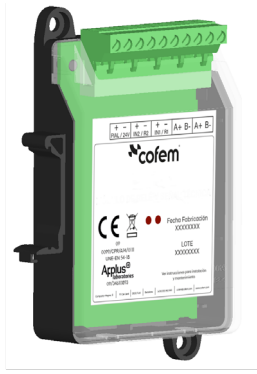

MDA1Y

1 RELAY OUTPUT MODULE

NEW

1 relay output module certified EN 54-18

Microprocessed algorithmic addressable loop device (with short-circuit isolator)

The module loop powered but it requires an auxiliary 30V supply power to provide the necessary energy to the devices controlled by the relays. It supervise the voltage presence in the auxiliary supply line of 30V and in the output of the supervised relays.

The module is protected by 0,9 A resettable fuse and each output is supervised by 0,5 A.

The red Led blinking indicates communication with the control panel, the lit green LED indicates the activation of one or both relays.

It is a module with simultaneous activation (with a single function) of two outputs relay , both in its type of application

(siren, activation or pre-alarm), as well as in its timing and combination of sensors that activate them.

The R1 output relay is supervised by a final line resistance of 33 kΩ that indicate the state of opened line or short circuit. The R2 output relay operate as a dry contact NO and NC, not supervised, It is usually used to activate the fire-resistant doors electromagnets. The installation of an external power supply is recommended in case to use more than 10 electromagnets together.

The device is supplied in a rectangular heat-resistant ABS box, to be mounted on surface or on DIN rail.

The module is certified according to EN 54-18 Standard, and CE labelled according to the European Regulation of Construction Products (UE) N° 2024/3110.

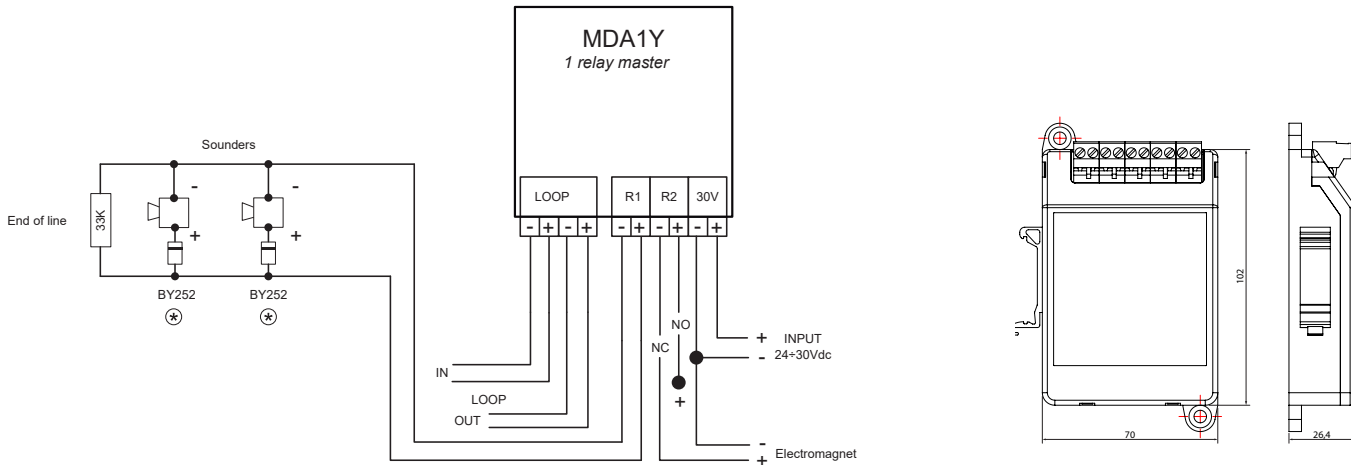

★ It depends on if the sounder has diode incorporated

TECHNICAL FEATURES			
Module power supply	loop 24 - 35V with polarity	Communication indicator	Red light
Standby current	1mA	Humidity	20 - 95% RH
Short-circuit isolator	Yes	Temperature	-10°C - +50°C
Relay supervision voltage	7V with reverse polarity	Dimensions (totals)	82,5x123x26,4mm
Relay output voltage by external supply	24+30Vdc	Dimensions	EN 54-18
Activation signal	Green light	IP protection	IP30

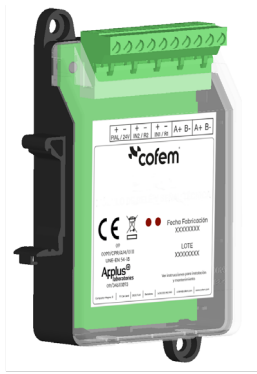

MDA2Y

2 RELAYS OUTPUT MODULE

NEW

2 relays supervised output module certified EN 54-18

Microprocessed algorithmic addressable loop device (with short-circuit isolator).

The module takes the power supply from the loop, but it requires an auxiliary 30 V supply to give the necessary energy to the devices controlled by the relays. It monitors the presence of voltage in the auxiliary supply line of 30V and in the output of the monitored relays.

The module is protected by 0,9 A resettable fuse and each monitored output by 0,5 A.

The flashing of the transparent red LED indicates communication with the control panel. Illumination of the green LED indicates the actuation of a relay.

It is a module with two relay outputs of independent activation (two functions), not only in their type of application (sounder, switches or crossed relay), but also in their timing and in the combination of sensors that activate them.

In the standby state, the MDA2Y monitors both external line by means of a 33 kΩ resistance, indicating the state of open line or crossed line.

The device is supplied in a rectangular heat-resistant ABS box, to be mounted on surface or on DIN rail.

The module is certified according to EN 54-18 Standard, and CE labelled according to the European Regulation of Construction Products (UE) N° 2024/3110.

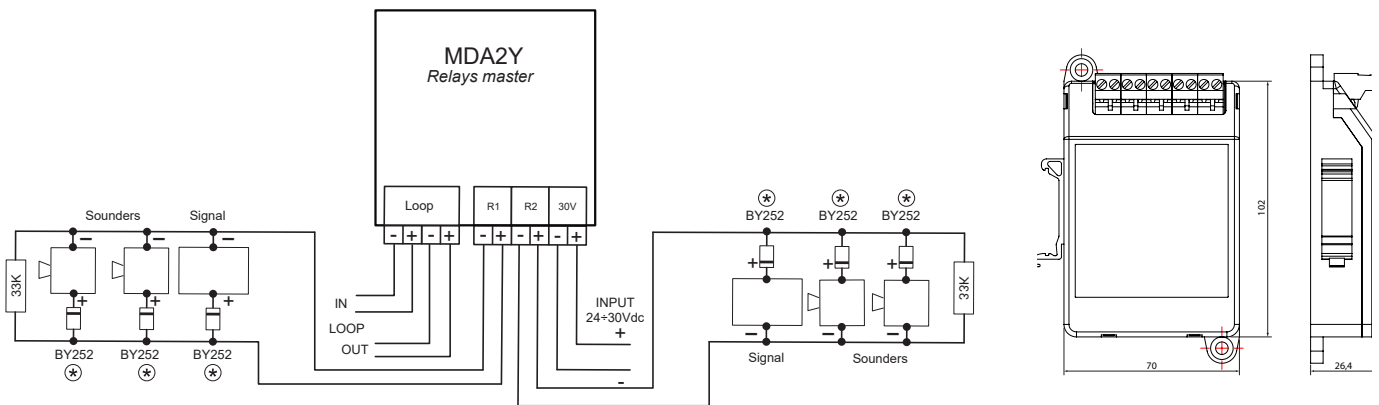

* It depends on if the sounder has diode incorporated

TECHNICAL FEATURES			
Module power supply	loop 24 - 35V with polarity	Communication indicator	Red light
Standby current	1mA	Humidity	20 - 95% RH
Short-circuit isolator	Yes	Temperature	-10°C - +50°C
Relay supervision voltage	7V with reverse polarity	Dimensions (totals)	82,5x123x26,4mm
Relay output voltage by external supply	24±30Vdc	Standard	EN 54-18
Activation signal	Green light	IP protection	IP30

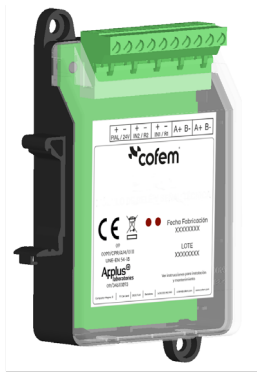

MYOA / MYOAF

OUTPUT INPUT MODULE

NEW

Input and output module certified EN 54-18

Microprocessed algorithmic addressable device (with short-circuit isolator) installed as another element inside the loop.

This module has one relay output fed by external 30V and one technical signal input to distinguish the open or closed state of a dry contact. The Module is protected by 0,9 A resettable fuse and the relay by 0,5 A.

This module is electrical fed through the loop connection, but it is required auxiliary 30V for feeding the equipment's connected to the relay output "R1". The relay is configured with only one function (sounder, switched or crossed relay), but also in its timing and in the combination of sensors that activate it. The module monitors the presence of voltage in the auxiliary supply line of 30V and in the output of the monitored relay. The voltage output of the relay is 30V.

The technical signal input has a 10 kΩ resistor connected in series with the dry contact. In quiescent condition, the contact has to be open, and in anomaly condition, the contact has to be closed. In the input (marked with IN2), the closed contact is detected as ALARM condition.

There is also the MYOAF version, which is identical to the MYOA, except that the closed contact is detected as a fault.

The MYOA supervises each external line (relay output and technical signal input) through a 33kΩ each one, which allows indication of open or closed electrical connection status.

The flashing of the transparent red LED indicates communication with the control panel, the fix light of red led indicates the alarm status of the input, and the illuminated green LED indicates the activation of the relay.

The Relay and Technical Signal Module is placed in a rectangular, head-resistant ABS box, to be mounted on surface or on DIN rail.

The module is certified according to EN 54-18 Standard, and labelled according to the European Regulation of Construction Products (UE) N° 2024/3110.

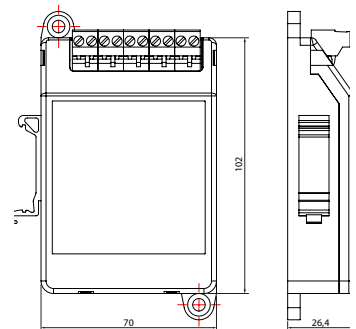
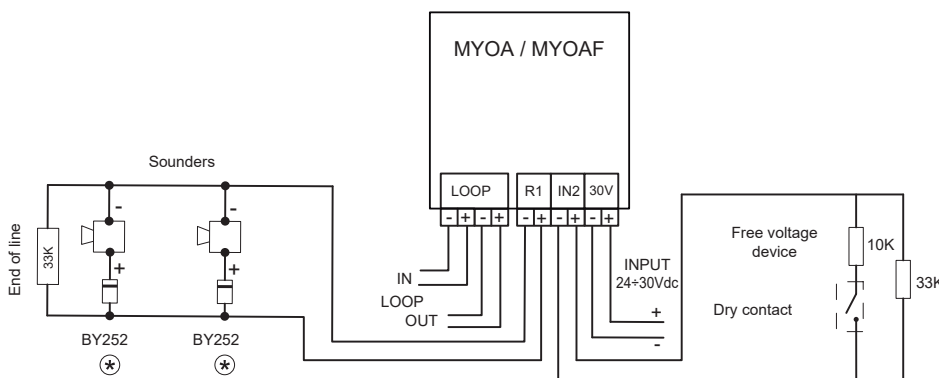

★ It depends on if the sounder has diode incorporated

TECHNICAL FEATURES			
Module power supply	loop 24 - 35 with polarity	Communication/Alarm indicator	Red light
Standby current	1mA	Humidity	20 - 95% RH
Short-circuit isolator	Yes	Temperature	-10°C - +50°C
Supervision voltage	7V with reverse polarity	Dimensions (totals)	82,5x123x26,4mm
Remote indicator output	No	Standard	EN 54-18
Activation indicator	Green light	IP protection	IP30
Relay output voltage by external supply	24 ÷ 30 Vdc		



MDA2YLT

2 RELAY OUTPUT MODULE

2 relay dry contact output module

Microprocessed and algorithmic-addressable module (with short-circuit insulator) which is installed as one more element in the loop.

The modules are powered by the loop connection, requiring no outside power. The blinking red transparent LED shows there is communication with the control panel. The fixed lit red

transparent LED indicates that one or both relays have been triggered.

This is a module with two relay outputs that are separately activated (two functions), independent timing, as well as a combination of sensors that activate them. The R1 and R2 outputs are voltage free C/ NC/ NA. Using this module, we can control fire doors and gates.

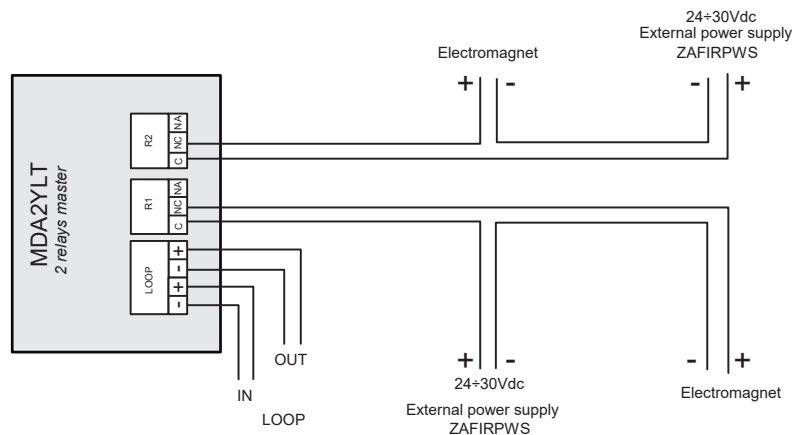
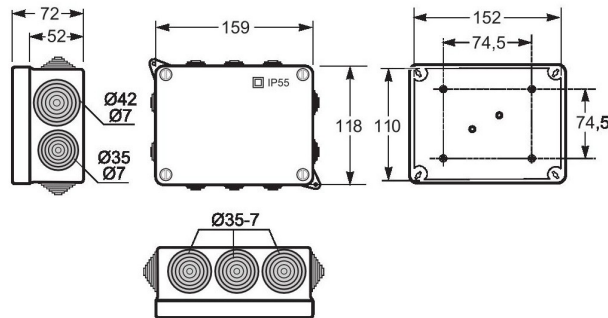

TECHNICAL FEATURES			
Module power supply	loop 24 - 35 with polarity	Communication indicator	Red light (blinking)
Standby current	1mA	Humidity	20 - 95% RH
Activated consumption	4mA	Temperature	-10°C - +50°C
Loop isolator	Yes	Dimensions	159x118x72mm
Maximum resistive load	5A / 250VAC	IP protection	IP55
Activation indicator	Red light (fixed)		



KMAY32

MODULE TO CONNECT DETECTORS/ALARM CALL POINTS

Module for connecting conventional detectors and alarm call points

Microprocessed and algorithmic-addressable module (with short-circuit insulator) which is installed as one more element in the loop.

This module allows the connection of conventional detectors and/or alarm call points in an algorithmic-addressable fire detection system, performing the interface function between an algorithmic-addressable control panel and a conventional system. Up to a maximum of 10 conventional alarm call points can be installed on the strip of "Area C". The "D Area" strip allows a maximum of 32 temperature detectors (A50, A30X range) or 32 components between smoke detectors (A50, A30X range) and conventional alarm call points. Both strips supervise the line using a 4K7 end-of-line resistor. It thus indicates the status of the open line, crossed line, detector alarm or alarm call point alarm.

It has a microswitch for setting the area thresholds;

- Open line threshold (pin microswitch 1-2).
- Detector alarm triggered threshold (pin microswitch 3-4).
- Alarm call point triggered threshold (pin microswitch 5).

The blinking of the red transparent LED indicates communication with the control panel, and if it stays on in indicates the status of the alarm of a detector or of a alarm call point connected to that module.

This module has an output for the activation of a remote pilot, which is activated when it is in alarm state.

This module is powered by the loop connection and requires a 24V auxiliary power supply to power the areas, said voltage is supervised by the microcontroller.

Rectangular boxes made of heat-resistant ABS are available on order.

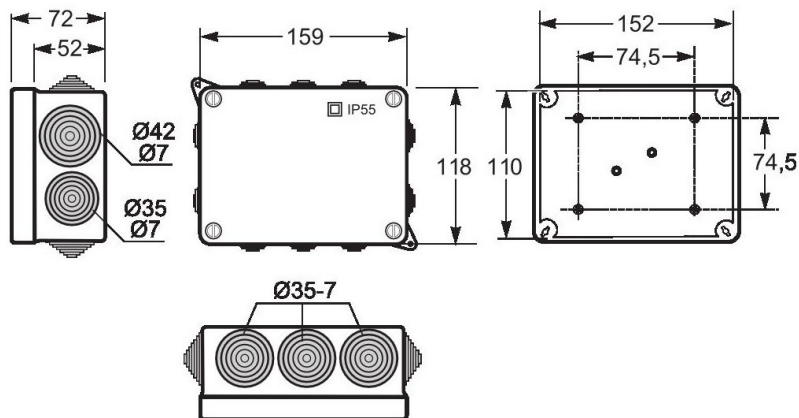

TECHNICAL FEATURES			
Module power supply	loop 24 - 35V with polarity	Activation indicator	Red led (fixed)
Auxiliary 24V power supply	20 - 30V	Communication indicator	Red led (blinking)
Standby consumption	1,5mA	Humidity	20 - 95% RH
Short-circuit isolator	Yes	Temperature	-10°C - +50°C
Area voltage	22V with polarity	Dimensions	159x118x72mm
Remote indicator output	Yes	IP protection	IP55

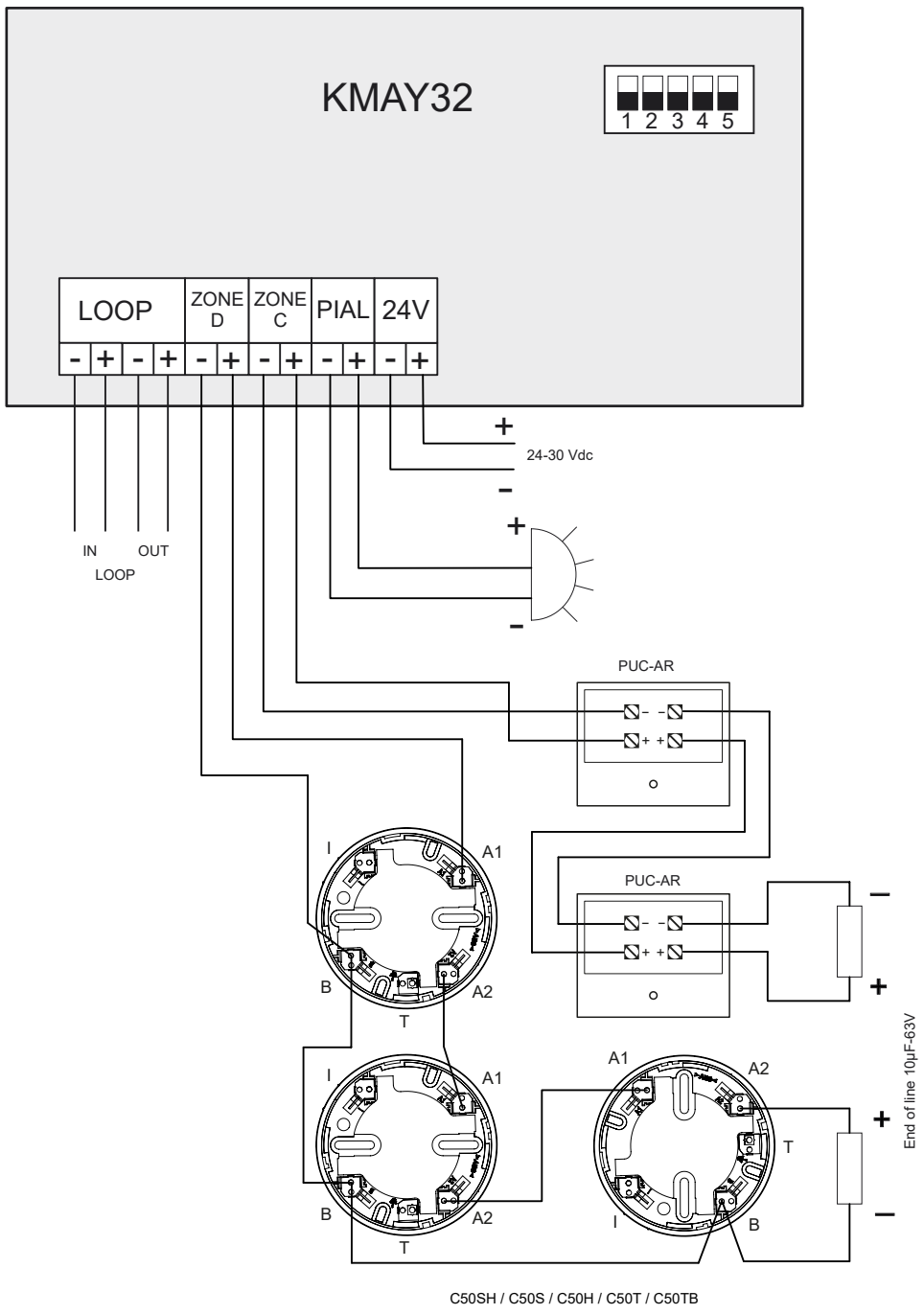

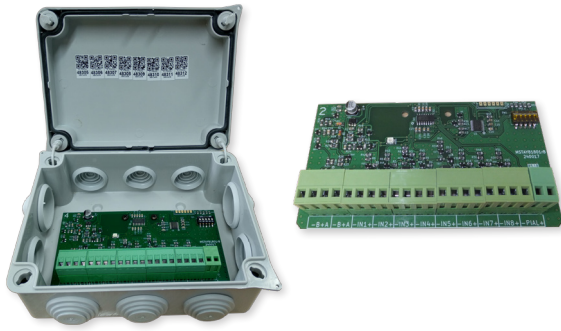

MSTAY8

MODULE WITH 8 INPUTS

8-input module to supervise equipment

Microprocessed and algorithmic-addressable module (with short-circuit insulator) which is installed as one more element in the loop.

It has eight inputs to monitor equipment external to the system.

It is typically applicable for signalling the status of other detection systems in which there could be a connection to flow sensors in the case of sprinkler installations, travel path end-stops in the case of fire doors, lifts, tank levels, pressure units, etc.

These inputs are configurable by microswitch in the following manner:

- Supervised (pin 1 microswitch set to ON); the outside line in supervised standby state by means of a 33kΩ resistor, indicating the status of the line or crossed line. Connecting a parallel 10kΩ resistor will activate the related input.
- Active by closed contact (pin 1 microswitch set to OFF and pin 3 microswitch set to OFF); the input in standby must be with the contacts open, in case of event the input contacts

must be crossed. This will be the factory setting.

- Active by open contact (pin 1 microswitch set to OFF and pin 3 microswitch set to ON); the input in standby must be with the contacts crossed, in case of event the contacts must be opened.

Using pin 2 of the configuration microswitch we will select the type of event that the module will send to the control panel: ON Fault and OFF Alarm.

The configuration of the inputs is common to all of them.

The blinking of the transparent red LED indicates communication with the Lyon control panel and also if it stays lit it indicates the activation of one or several inputs. This module has an output for the activation of a remote pilot, which is activated when it is in alarm state. The Technical Signals module is powered by the connection to the loop.

Rectangular boxes made of heat-resistant ABS are available on order.

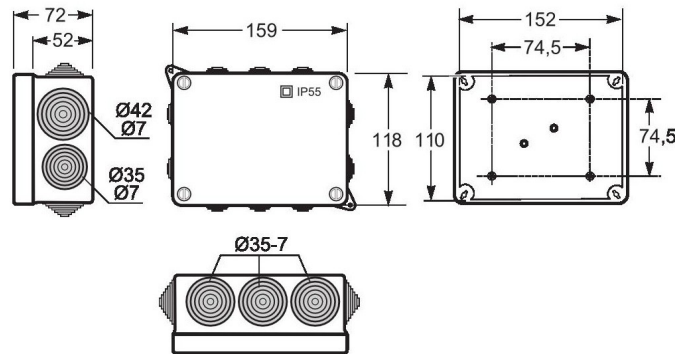

TECHNICAL FEATURES			
Module power supply	loop 24 - 35 with polarity	Short-circuit isolator	Yes
Supervision-free mode standby consumption		Supervision voltage	5V with reverse polarity
Active by closed contact	2mA	Remote indicator output	Yes
Active by open contact	5mA	Activation indicator	Red led (fixed)
Supervised mode standby consumption	2,5mA	Communication indicator	Red led (blinking)
Non supervision-free mode alarm consumption		Humidity	20 - 95% RH
Active by closed contact	14mA	Temperature	-10°C - +50°C
Active by open contact	11mA	Dimensions	159x118x72mm
Supervised mode alarm consumption	14mA	IP protection	IP55

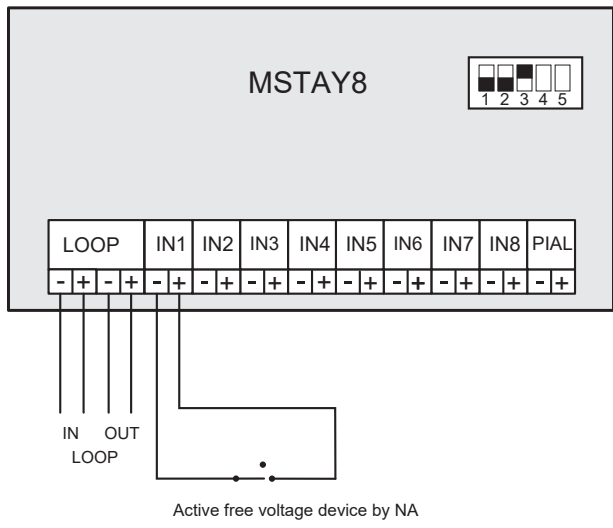
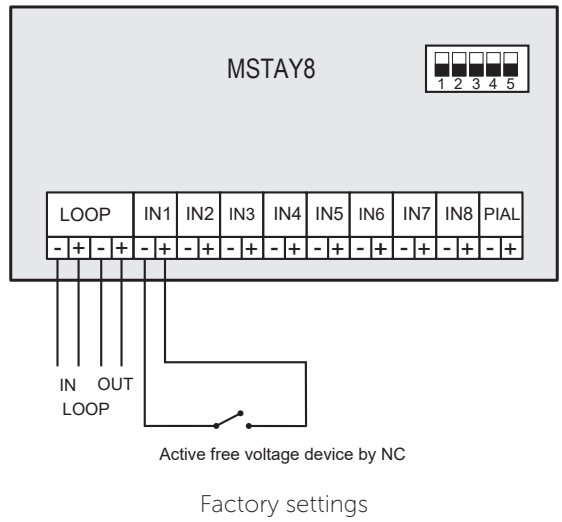
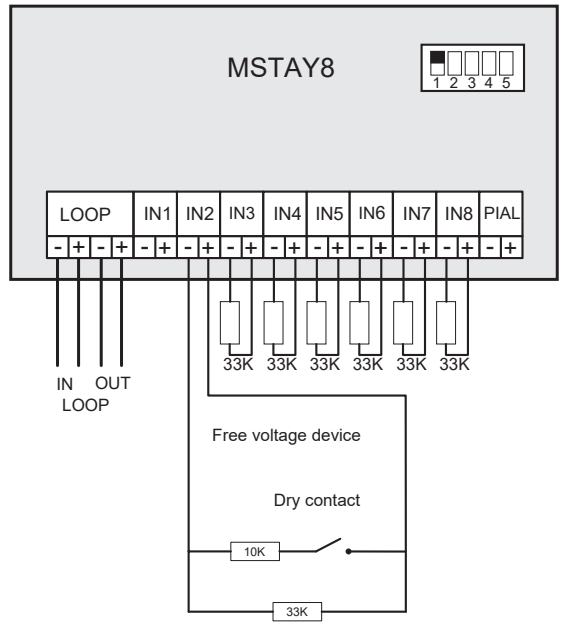



A50xxLD

DETECTORS WITH LIGHT AND SOUND



Algorithmic detectors with light and acoustic alarm certified EN 54-23 and EN 54-3

A50 family fire sensor with additional functionality of visual alarm device (Light) and fire sounder (sound) integrated in a single device.

Within the A50 range, multiple combinations of optical, heat, optical-heat and UL-certified short-circuit isolator detection are possible.

To these functionalities can be added the visual alarm device functionality (A50xxL) based on EN 54-23, the fire sounder functionality (A50xxD) based on EN 54-3, or both (A50xxLD).

The different models are:

A50SHILD: A50SHI with light and sound
 A50SILD: A50SI with light and sound
 A50HILD: A50HI with light and sound
 A50SHID: A50SHI with sound
 A50SID: A50SI with sound
 A50HID: A50HI with sound
 A50SHIL: A50SHI with light
 A50SIL: A50SI with light
 A50HIL: A50HI with light

FEATURES

- Different models with optical, heat or optical-heat sensor.
- Built-in short-circuit isolator.
- Low-profile base (not included).
- Capacity of up to 64 devices per loop in Lyon control panel.
- The control panel allows setting the optical and acoustic alarm output with two different intensity levels for rooms of 21 or 30 m².
- Possibility of connection to a remote action indicator.
- Easy to connect.
- Red and yellow bicolor LED.
- Indication, by the red LED, of the communication with the control panel (single flashing), as well as of the alarm status (LED on).
- Indication, by the yellow LED (single flashing), of the activation of the short-circuit isolator or the failure to communicate with the control panel.
- Indication of the sensor's dirt status on the control panel display (the sensor can differentiate between rapid signal increases due to alarms and small, slow, sustained increases due to accumulation of dust and dirt).
- Easy-to-install head and base, interchangeable on the entire A50 range, made of heat-resistant white ABS.
- UL certified according to EN 54-5 class A2R, EN 54-7, EN 54-17, EN 54-3 and EN 54-23 with CE marking according to the European Construction Products Regulation (EU) N° 2024/3110.

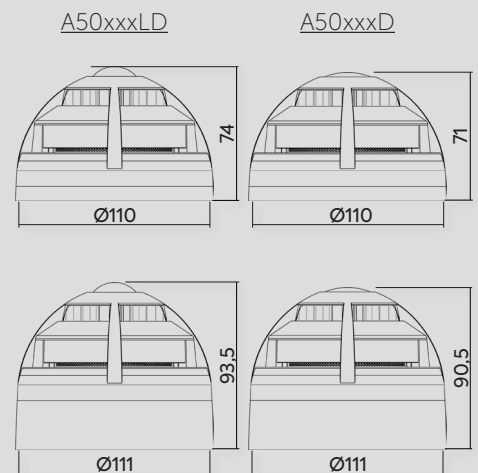

TECHNICAL FEATURES

Supply	18 - 30V	Sound power	high level: 87 dB-1m; Tone sweep 1s 2650-3000Hz
Standby current	0,35mA		mid level: 84 dB-1m; Tone sweep 1s 2650-3000Hz
Alarm current	15mA	Visual device	high level: C-3-7,65 0,5 Hz with synchronised pulses (equivalent to 30 m ² rooms)
Operative temperature	-10°C - +50°C		mid level: C-3-6,5 0,5 Hz
Dimensions (without base)	Ø109x63 (A50xxLD) Ø109x66 (A50xxD)		(equivalent to 30 m ² rooms)
IP protection	IP21C		
Certification (light and sound)	EN 54-23 and EN 54-3		



A50ZSLDR



A50ZSDDR

A50ZSLDR A50ZSDDR

ALARM DEVICES

Addressable alarm devices certified EN 54-23 and EN 54-3

Base for A50 algorithmic-addressable detectors with EN 54-23 certified visual alarm base and EN 54-3 sounder supplied directly from the loop.

There are 2 models available (detector not included):

- A50ZSLDR: D50 base with sound and light base, addressable.
- A50ZSDDR: D50 base with sound, addressable.

This device needs an addressable detector "with SIRDR functionality" (standard detectors do not have this functionality) which will allow it to operate as a relay associated to this detector.

Typical uses of the A30XZSDDR and A30XZSLDR are spaces that require integrated fire detection equipment with sounder and visual alarm, such as hotel rooms fitted out for clients with hearing impairments, waiting rooms, nursing rooms, etc.

The coverage of the assembly should not exceed the coverage of the fire detector with which it is installed, unless there is a reason or use that justifies it.

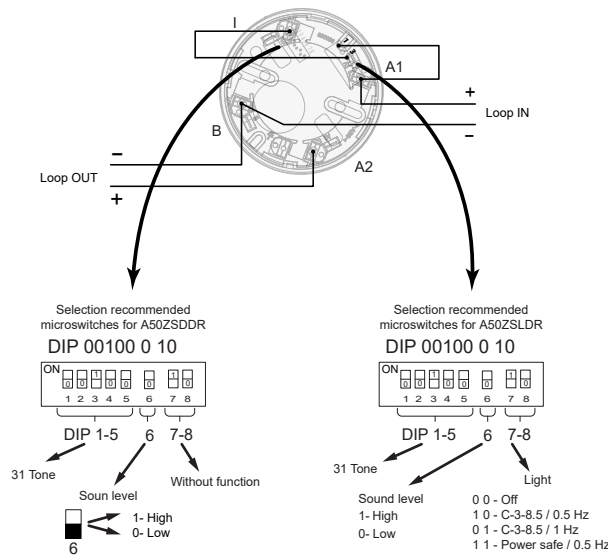

TECHNICAL FEATURES	A50ZSDDR	A50ZSLDR
Supply	18 - 30V with polarity	
Standby consumption	0mA	
Alarm consumption	5mA / 6mA (Low/High dB)	19mA / 20mA (Low/High dB)
Operative temperature	-10°C - +55°C	
Dimensions	Ø112x43mm (without detector)	
IP protection	IP21C	
Sound intensity	Low 90 / High 96 dB - 1m	
Tones	31 types	
Standard	EN 54-3	EN 54-23 and EN 54-3
Flash	-	0,5Hz (60ms)



A30XZSLDR



A30XZSDDR

A30XZSLDR A30XZSDDR

ALARM DEVICES

Addressable alarm devices certified EN 54-23 and EN 54-3

Base with EN 54-23 visual alarm certified for A30X series, EN 54-3 sound certified and base detector.

There are 2 models available (detector not included):

- A30XZSLDR: A30XZ base with sound and light base, addressable.
- A30XZSDDR: A30XZ base with sound, addressable.

This device needs an addressable detector "with SIRDR functionality" (standard detectors do not have this functionality) which will allow it to operate as a relay associated to this detector.

Typical uses of the A30XZSDDR and A30XZSLDR are spaces that require integrated fire detection equipment with sounder and visual alarm, such as hotel rooms fitted out for clients with hearing impairments, waiting rooms, nursing rooms, etc.

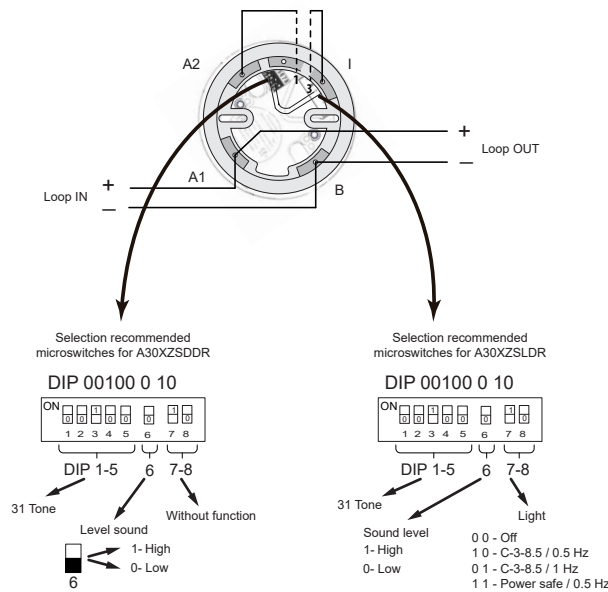

TECHNICAL FEATURES	A30XZSDDR	A30XZSLDR
Power supply		18 - 30V with polarity
Standby consumption		0mA
Alarm consumption	5mA / 6mA (Low/High dB)	19mA / 20mA (Low/High dB)
Operative temperature		-10°C - +55°C
Dimensions		Ø112x43mm (sin detector)
IP protection		IP21C
Sound intensity		Low 90 / High 96 dB - 1m
Tones		31 types
Standard	EN 54-3	EN 54-23 and EN 54-3
Flash	-	0,5Hz (60ms)

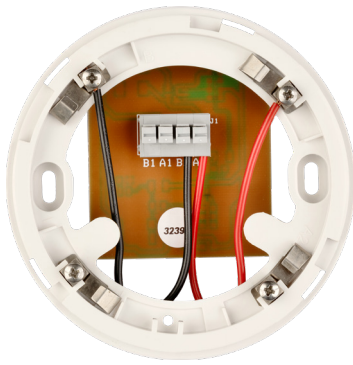

KABY

LOOP ISOLATOR MODULE

Loop isolator module certified EN 54-17

Microprocessed algorithmic element installed as another element inside the loop (It is not addressable – There is not need to configure this element).

This is a protection element that is connected into the detection loop, with the aim of isolating stretches with crossed line failures, and allowing therefore the rest of the loop to operate normally.

It is supplied installed inside of a high base. This assembly allows having it in the same place as the detector, making easy the connection of the loop wiring.

We recommend installing a module or element with isolator, minimum every 32 elements of the loop.

The base has two stickers in the outer side with the word "KABY" to allow easy recognition.

The element is feed from the loop connection.

The module is certified according to EN 54-17 Standard, and CE labelled according to the European Regulation of Construction Products (UE) N° 2024/3110.

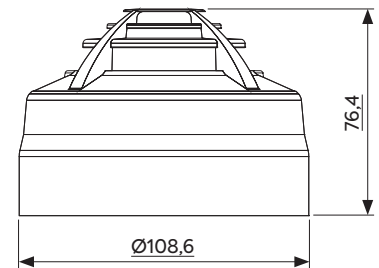
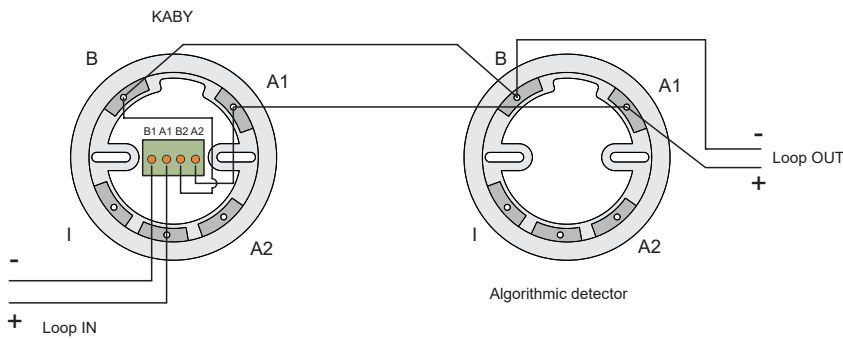

Assembly for A30XHA

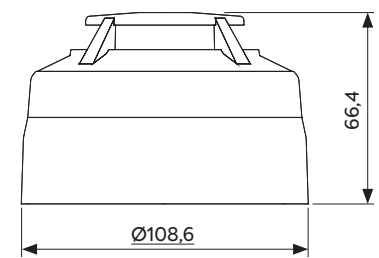

Assembly for A30XTA / A30XHAS

TECHNICAL FEATURES			
Power supply	24 - 35V with polarity	Humidity	20 - 95% RH
Standby current	110µA	Temperature	-10°C - +50°C
Short-circuit isolator	Yes	Standard	EN 54-17
Remote indicator output	No	IP protection	IP 30



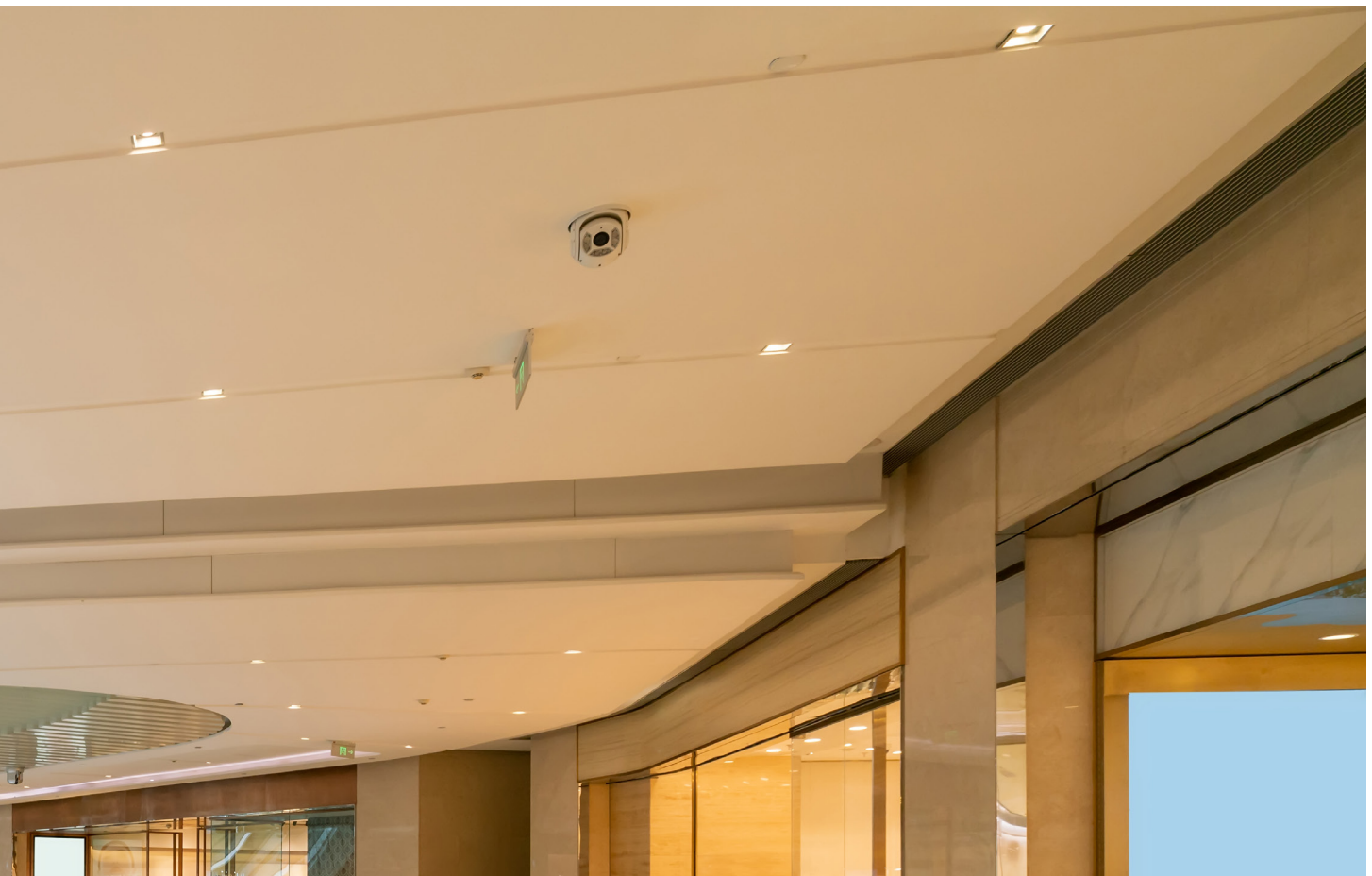

CONVENTIONAL SYSTEM



SILVER

CONVENTIONAL CONTROL PANEL

Conventional Fire detection and Fire alarm control panel, EN 54-2 and EN 54-4 certified

Conventional fire detection and fire alarm control panel with up to 16 zones and 16 configurable relay outputs; this control panel is characterized by having independent zones and relay outputs.

For zones, different models are available to adapt in the most precise way to the needs of each installation with 2, 4, 8, 12 or 16 zones.

For relay outputs, the control panel supports up to 2 relay cards with 4 or 8 relays.

Additionally, there are two variants of relay cards: With all dry contact relay outputs or with all supervised relay outputs; the configuration of each relay is independent.

The control panel can be connected to the addressable loop of the Lyon system as another element.

Versions with Modbus, CRI, I-Link and Cofem 360 are available.

FEATURES

- Control panel with 2, 4, 8, 12 or 16 zone models with capacity to incorporate up to 32 elements per zone.
- Capacity to include 4, 8, 12 or 16 relay outputs. These relays can be supervised (wet contact output) or unsupervised (dry contact output NA/NC/COM).
- 2 independent general sounder outputs S1 and S2, supervised and with delayed activation between 0 and 10 minutes and protected by a self-resetting fuse.
- 1 dry contact alarm output with immediate activation named ALARM.
- 1 fault output, with dry contact and delayed activation between 0 and 10 minutes, protected by a resettable fuse named FAULT.
- 2 auxiliary 30VDC outputs, named 30V (non-resettable) and 30VR (resettable), both protected by a fuse, capable of providing external power to elements such as fire door electromagnets, external sirens, relay modules, etc.
- 2 supervised general sounder outputs, S1 and S2, with independent delay activation between 0 and 10 minutes, protected by resettable fuses.
- It includes, by default, the Spanish and English languages.
- Metal box with a front-bolted door, 13 28mm diameter pre-drills for wiring and space for 2 12V and 7Ah batteries.
- Dimensions 328x423x159mm (with cover).
- IP30 protection.
- Certified according to EN54-2/A1 and EN54-4/A1 regulations.

TECHNICAL FEATURES

Input voltage	110-230VAC	S1 output	30VDC 0,5A
Zone voltage	19-22,6VDC	S2 output	30VDC 0,5A
Maximum current (in alarm)	2A	Fault output	Dry contact NA/NC 0,5A
Batteries	2x12V, 7Ah	Output 30V + 30VR	0,5A
Maximum output current	2A	Environmental conditions	-10°C +50°C
Battery charger	500mA, 27VDC 20°C	Dimensions	328x423x159mm (with cover)
Elements per zone	32	Weight (without batteries)	5kg
Current per zone	2mA	Standards	EN 54-2/A1 y EN 54-4/A1
End-of-line resistor	4K7	Protection	IP30

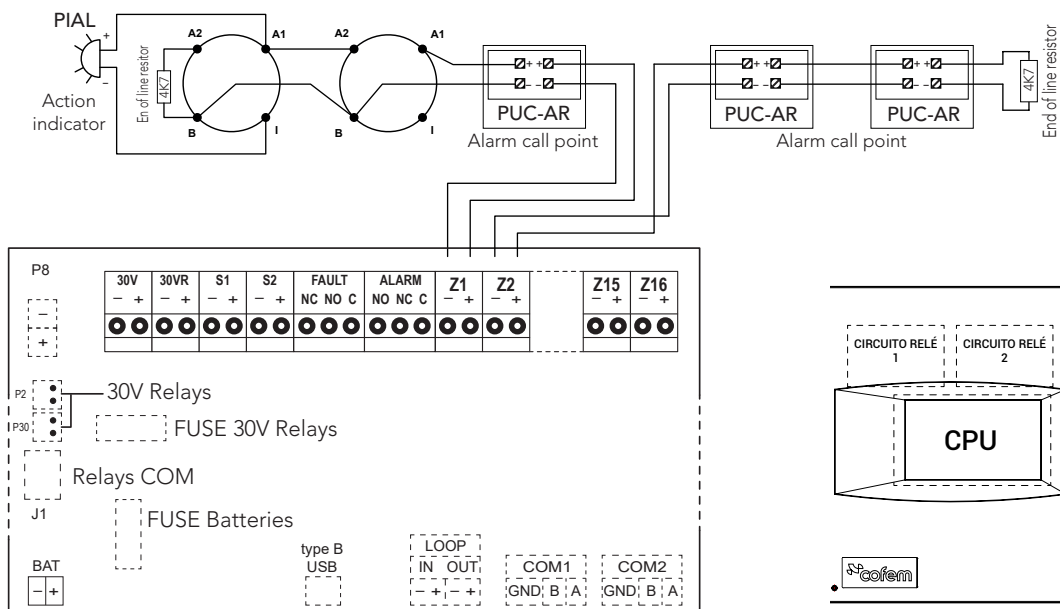

Wiring diagram CPU

* NOTE 1: The control panel has space for 2 relay cards of 4 or 8 relays each.

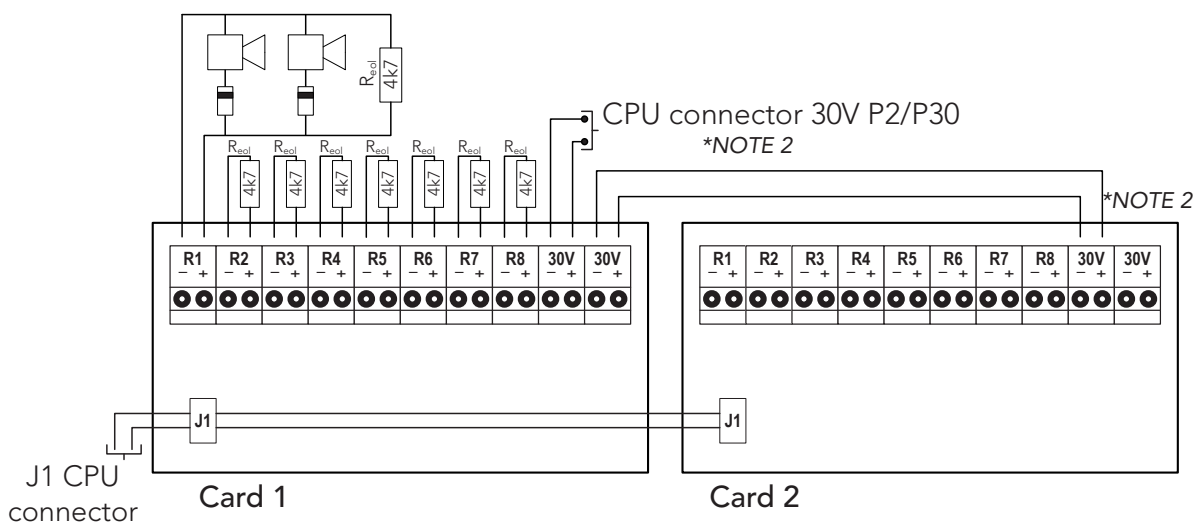

- * NOTE 2: Supervised relay cards can be supplied with an external 24-30Vdc power supply.
- * NOTE 3: Maximum output current of each relay 0.5A (autoreset fuse). Check that the total consumption of the cards does not exceed the capacity of the control panel or the external power supply.

Wiring diagram of supervised relay cards

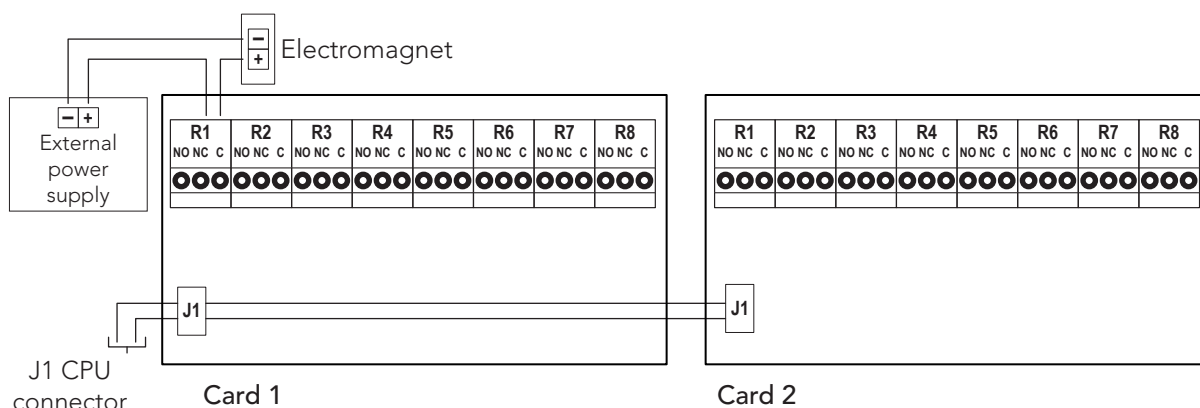

* NOTE 4: Each dry contact relay has a maximum capacity of 0.5A 30Vdc/230Vac.

Wiring diagram of supervised relay cards



CLVR

CONVENTIONAL CONTROL PANEL

Conventional Fire detection and Fire alarm control panel, EN 54-2 and EN 54-4 certified

Automatic conventional fire detection and fire alarm control panel. CLVR control panels features are common in all its models.

This control panel provides different versions to fit more accurately to the needs of each facility:

- CLVR 08Z: CLVR Control panel up to 8 zones.
- CLVR 12Z: CLVR Control panel up to 12 zones.

FEATURES

- Control panels up to 12 zones for conventional detectors and call points use.
- 2 supervised sounder outputs, delayed from 0 to 10 minutes, and protected by a fuse.
- 1 alarm output through a dry contact NO/NC (normally open / normally closed).
- 1 fault output through a dry contact NO/NC (normally open / normally closed).
- 2 auxiliary outputs 30V/DC supervised and protected by a fuse to feed external (magnetic fire doors, sounders, etc).
- Available testing mode to facilitate the quick and easy verification of the sensors and call points.
- It allows to configure the open line, alarm detector and alarm call point threshold, to adjust to the operation with other detectors.
- It allows to configure the last detection zone as a supervision input of a external protection fire system with a fault indication.
- Metallic chest with frontal bolted door, 4 pre drilled of 28 mm and one rectangular else of 140 x 20 mm for electric wiring and space for 2 batteries of 7Ah.
- RS485 MODBUS protocol on-demand.
- Possibility of software ON-LINE on PC using MODBUS functionality.
- CONTACTID on-demand.
- Certified according to EN 54-2 & EN 54-4 standards and CE mark .

TECHNICAL FEATURES

Input voltage	110/230 Vac 50/60Hz	End of line resistor	4K7
Output voltage	21V nominal	Sounder output voltage	30V/DC
Maximum consumption	155VA at 230 VAC	Fault output	Yes, dry contact
Batteries	2x12V 7Ah SLA	Environmental conditions	-10°C +50°C; IP30
Maximum voltage 30V output	0,75A/1,5A autoreset	Dimensions	368x336x96mm (with cover)
Battery charger	500mA 27V/DC 20°C	Weight (without batteries)	4,3Kg
Devices per zone	32	Standard	EN 54-2, EN 54-4 and EN 12094-1
Control panel power supply	2,2A	Sounder output fuse S1	1A/1,85A autoreset
Maximum current per zone	2mA (standby)	Sounder output fuse S2	1A/0,75A autoreset

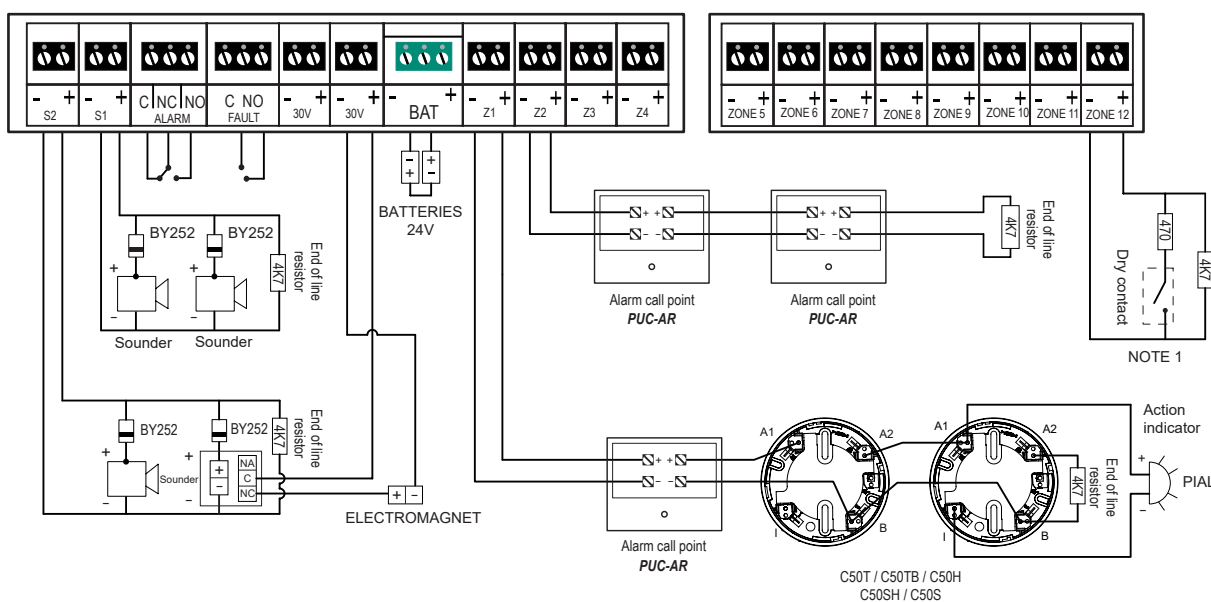
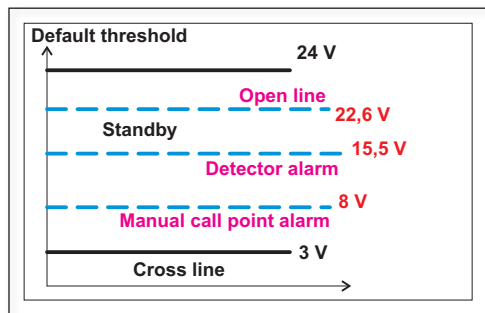
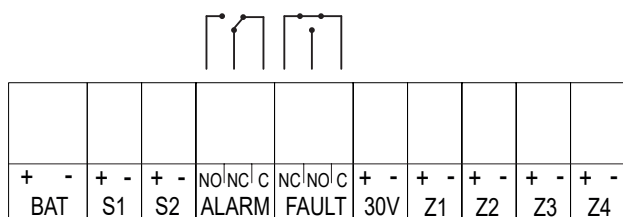

NOTE 1: Last zone configured for external system monitoring.

Example of general wiring diagram

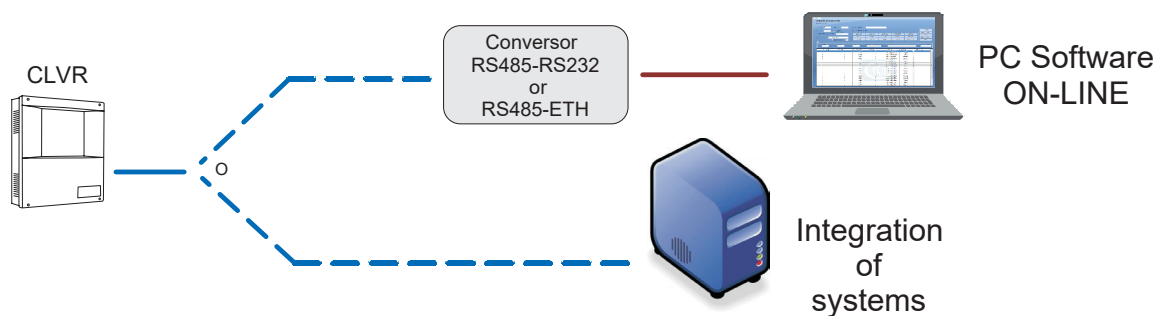

Example of connection for MODBUS functionality



I-LINK LITE

SOFTWARE FOR CONTROL PANEL SILVER

Configuration and management software for Silver control panels

I-LINK LITE is a PC software specifically designed for the configuration and management of conventional Silver control panels.

This system allows configuration through an intuitive graphical interface, facilitating the customization of the main functionalities of the control panels, and adapting to the particular needs of each installation.

FEATURES

- Compatibility with Windows operating systems.
- Advanced configuration of the main functionalities of the control panels.
- Customization of labels for zones and outputs.
- Programming of activation sequences of the main and logical outputs, adapted to different situations.
- Download and management of the control panel event history.

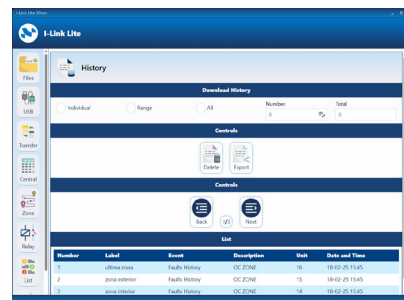
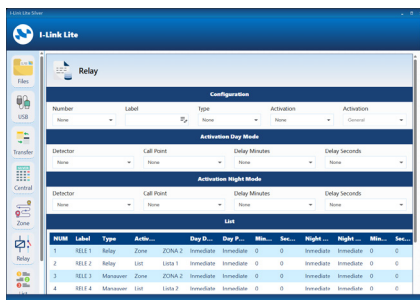
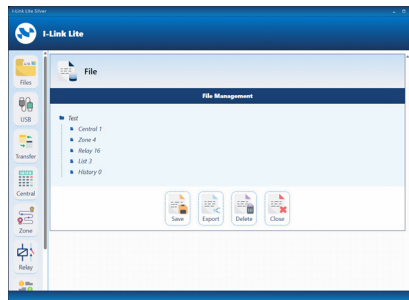

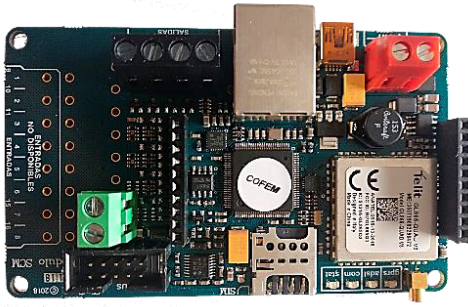

MCCRC

CONNECTION MODULE WITH CRI

Conventional module for connecting with Alarm Receiving Center.

EN 54-21 certified card that allows connection of the CLVR model conventional control panel with an Alarm Receiving Centre (ARC).

The following factory options are available which include the control panel with MODBUS functionality required for communication with the MCCRC card and the MCCRC card.

- CLVR08CRI
- CLVR12CRI

The MCCRC card is available for spare parts.

The MCCRC card can only be connected to CLVR control panels with MODBUS functionality.

FEATURES

- Certified EN 54-21.
- Communication with ContactID protocol.
- GPRS and ethernet connection (selectable).
- Notification to the ARC of selected and scheduled events.
- User notification via SMS, e-mail or customised mobile application.
- Software programming on PC via PC port or remote connection.
- Remote access and control of control panel status.



IRON

CONVENTIONAL CONTROL PANEL

Conventional Fire detection and Fire alarm control panel, EN 54-2 and EN 54-4 certified

Automatic conventional fire detection and fire alarm control panel.

This control panel provides different versions to fit more accurately to the needs of each facility:

IRON02: IRON control panel with 2 detection zones.

IRON04: IRON control panel with 4 detection zones.

FEATURES

- 2 or 4 zones control panels for use with conventional detectors and alarm call points.
- Up to 32 elements (with detectors and alarm call points) per zone.
- 2 supervised general sounder outputs, delayable from 0 to 7 minutes, each protected by a self-rearming fuse.
- 1 immediate alarm output using a NO/NC (Normally Open/Normally Closed) dry contact.
- 1 immediate fault output using a NO/NC (Normally Open/Normally Closed) dry contact.
- 1 auxiliary 30 V/DC output supervised and protected by a auto-resettable fuse for external power supply (fire door electromagnets, sirens, etc).
- It has a Test Mode to facilitate quick and easy testing of detectors and alarm call points.
- Allows open line, detector alarm and call points alarm thresholds to be configured to suit operation with other detectors.
- Metal box with front screwed door, 10 pre-drilled 28 mm holes for wiring, and space for 2 x 2 Ah batteries.
- Certified according to EN 54-2 and EN 54-4 with CE marking.

TECHNICAL FEATURES

Input voltage	110/230 Vac 50/60Hz	End of line capacitor	4K7
Output voltage	21V nominal	Output voltage S1	30V/DC 0,5A
Maximum consumption	65VA a 230V/AC	Output voltage S2	30V/DC 0,5A
Batteries	2x12V 2Ah SLA	Fault output	Yes, dry contact
Maximum voltage 30V output	0,5A	Environmental conditions	-10°C +50°C IP30
Battery charger	350mA 27V/DC 20°C	Dimensions	248x240x115mm
Devices per zone	32	Weight (without batteries)	2,2Kg
Control panel power supply	3A	Standard	EN 54-2 EN 54-4
Maximum current per zone	2mA (standby)		

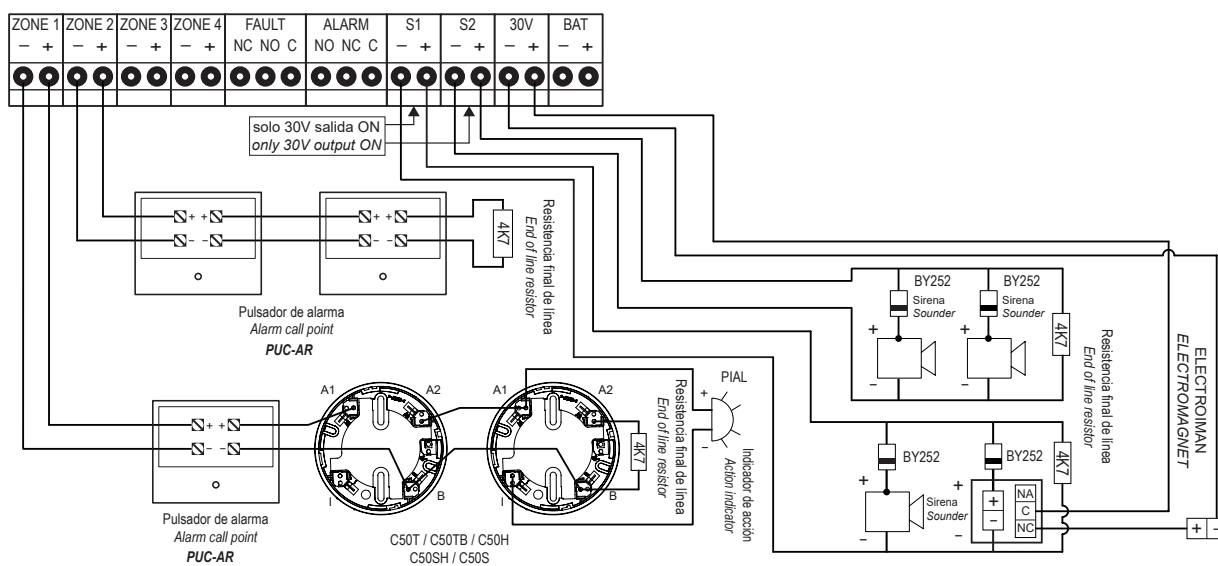
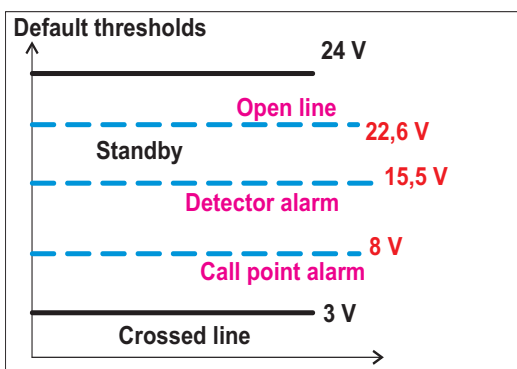

Wiring diagram for IRON control panel



PUCAR

RESETTABLE MANUAL CALL POINT

Addressable resettable alarm call point certified EN 54-11

Manual call point for the conventional fire detection system.

It has an indicator of action (red led) that illuminates in case of be manually operated (alarm).

FEATURES

- Resettable call point by pushing yellow button on the front side.
- Transparent protect or cover to avoid accidental false alarms.
- Immediate visual recognition of alarm status by the permanent activation of the LED, and the trigger of
- The yellow tab on the lower side of the activation face.
- According to EN 54-11 and CE mark according the European Regulation of Construction Products (UE) N° 2024/3110.

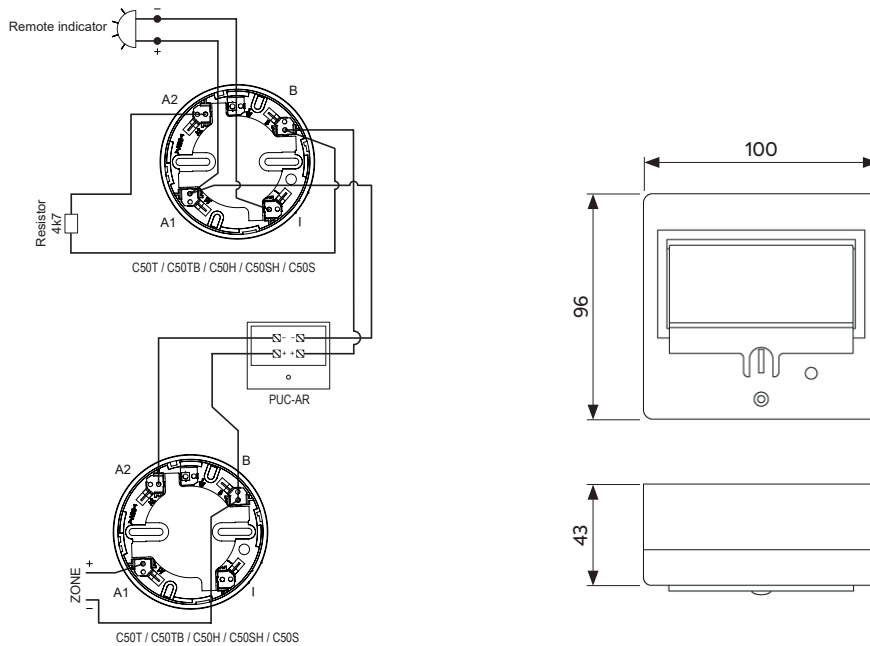

TECHNICAL FEATURES

Supply	24-35V with polarity	Humidity	20 - 95%RH
Standby consumption	0mA	Temperature	-10°C - +50°C
Alarm consumption	35mA	Standard	EN 54-11
Activation signal	Red led	IP protection	IP50
Remote indicator output	No		



C50SH

CONVENTIONAL SMOKE AND HEAT DETECTOR (MULTI-SENSOR)

Conventional smoke and heat detector certified EN 54-5 and EN 54-7

Conventional smoke and Heat detector (Multi-Sensor).

The C50 family of detectors are based on a new refined aesthetic that integrates the latest electronic technology with new, more efficient detection algorithms and a three-dimensional design that makes it more robust against environmental dirt.

The C50 family allows multiple combinations between smoke and heat detection.

The C50SH model is a detector with two different types of sensors: An smoke sensor and a heat sensor.

The smoke sensor is specially designed to detect the presence of combustion aerosols in a three-dimensional design that makes it more robust against dirt.

Regarding heat sensor, it allows the thermovelocimetric response of the detector, reaching the alarm status with a static temperature of 60°C in the case of slow fire developments.

FEATURES

- Smoke and heat sensor (Multi-Sensor).
- Low profile, total height less than 55 mm (including low base).
- Also available with high base for 20 mm tube.
- Possibility of connection to a remote action indicator.
- Easy connection, without polarity.
- Red LED on to indicate its alarm status.
- Standby status signalled by simple flashing of the red led every 10 seconds.
- High level of dirt status signalled by double flashing of the red LED every 10 seconds.
- Easy installation of head and plinth, interchangeable throughout the C50 family, and made of white heat-resistant ABS.
- Certified by AENOR according to Standard EN 54-5 class A2R and EN 54-7 with CE marking according to the European Regulation on Construction Products (EU) N° 2024/3110.

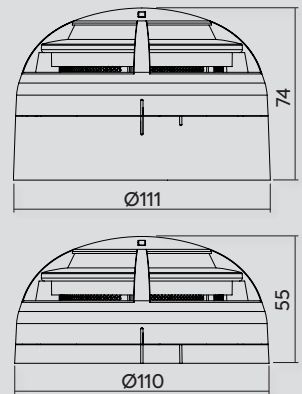

TECHNICAL FEATURES

Power supply	12-30V without polarity	Humidity	20 - 95%RH
Standby current	35µA (at 18V)	Operative temperature	-10°C - +50°C
Alarm current	30mA (at 18V)	Storage temperature	-10°C - +55°C
Activation signal	Red light	Sensitivity	EN 54-7/EN 54-5 Class A2R
Remote indicator	Yes	IP protection	IP20
		Coverage according with ISO 7240-14	7,2m (radius) / 100m2
Coverage area	104m² (subject to local regulation)	Installation height	15m (subject to local regulation)



C50S

CONVENTIONAL SMOKE DETECTOR

Conventional smoke detector certified EN 54-7

Conventional smoke detector

The C50 family of detectors are based on a new refined aesthetic that integrates the latest electronic technology with new, more efficient detection algorithms and a three-dimensional design that makes it more robust against environmental dirt.

The C50 family allows multiple combinations between smoke and heat detection.

The C50S model is a detector with a smoke sensor.

The sensor is specially designed to detect the presence of combustion aerosols in a three-dimensional design that makes it more robust against dirt.

FEATURES

- Smoke sensor.
- Low profile, total height less than 42 mm (including low base).
- Also available with high base for 20 mm tube.
- Possibility of connection to a remote action indicator.
- Easy connection, without polarity.
- Red LED on to indicate its alarm status.
- Standby status signalled by simple flashing of the red led every 10 seconds.
- High level of dirt status signalled by double flashing of the red LED every 10 seconds.
- Easy installation of head and base, interchangeable throughout the C50 family, and made of white heat-resistant ABS.
- Certified by AENOR according to Standard EN 54-7 with CE marking according to the European Regulation on Construction Products (EU) N° 2024/3110.

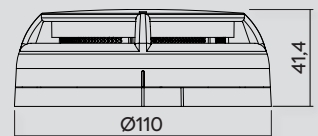
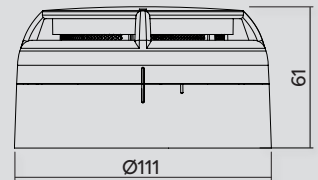

TECHNICAL FEATURES

Power supply	12-30V without polarity	Humidity	20 - 95%RH
Standby current	35µA (at 18V)	Operative temperature	-10°C - +50°C
Alarm current	30mA (at 18V)	Storage temperature	-10°C - +55°C
Activation signal	Red light	Sensitivity	EN 54-7
Remote indicator	Yes	IP protection	IP20
Coverage area	104m ² (subject to local regulation)	Installation height	15m (subject to local regulation)



C50H

CONVENTIONAL HEAT DETECTOR

Conventional heat detector certified EN 54-5

Conventional heat detector

The C50 family of detectors are based on a new refined aesthetic that integrates the latest electronic technology with new, more efficient detection algorithms and a three-dimensional design that makes it more robust against environmental dirt.

The C50 family allows multiple combinations between smoke and heat detection.

The C50H model is a detector with a heat sensor.

The heat sensor allows the detector's thermovelocimetric response, reaching the alarm status with a static temperature of 60°C in the case of slow fire developments.

FEATURES

- Heat sensor.
- Low profile, total height less than 42 mm (including low base).
- Also available with high base for 20 mm tube.
- Possibility of connection to a remote action indicator.
- Easy connection, without polarity.
- Red LED on to indicate its alarm status.
- Standby status signalled by simple flashing of the red led every 10 seconds.
- Easy installation of head and base, interchangeable throughout the C50 family, and made of white heat-resistant ABS.
- Certified by AENOR according to Standard EN 54-5 class A2 with CE marking according to the European Regulation on Construction Products (EU) N° 2024/3110.

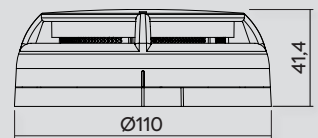
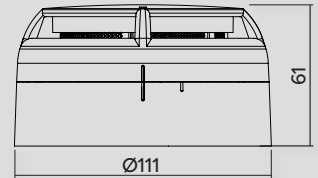

TECHNICAL FEATURES

Power supply	12-30V without polarity	Humidity	20 - 95%RH
Standby current	35µA (at 18V)	Operative temperature	-10°C - +50°C
Alarm current	30mA (at 18V)	Storage temperature	-10°C - +55°C
Activation signal	Red light	Sensitivity	EN 54-5 Class A2R
Remote indicator	Yes	IP protection	IP20
Coverage area	52m ² (subject to local regulation)	Installation height	6m (subject to local regulation)



C50T / C50TB

CONVENTIONAL TEMPERATURE DETECTOR

Conventional temperature detector certified EN 54-5

Conventional temperature detector.

The C50 family of detectors are based on a new refined aesthetic that integrates the latest electronic technology with new, more efficient detection algorithms and a three-dimensional design that makes it more robust against environmental dirt.

The C50 family allows multiple combinations between smoke and heat detection.

The C50T and C50TB models are detectors with a temperature sensor.

The temperature sensor of C50T is set to reach the alarm status with a static ambient temperature of 60°C.

In certain circumstances, the premises or building may require detectors that go into alarm status at a temperature higher than normal. In this case, the C50TB temperature sensor responds according to the ambient temperature, reaching the alarm status when the static temperature is 70°C in the case of slow fire developments.

FEATURES

- Heat sensor.
- Low profile, total height less than 42 mm (including low base).
- Also available with high base for 20 mm tube.
- Possibility of connection to a remote action indicator.
- Easy connection, without polarity.
- Red LED on to indicate its alarm status.
- Easy installation of head and base, interchangeable throughout the C50 family, and made of white heat-resistant ABS.
- Certified by AENOR according to Standard EN 54-5 class A2 with CE marking according to the European Regulation on Construction Products (EU) N° 2024/3110.

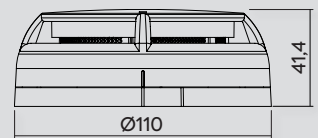
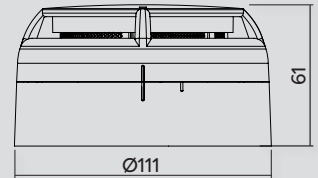

TECHNICAL FEATURES

Power supply	12-30V without polarity	Humidity	20 - 95%RH
Standby current	35µA (at 18V)	Operative temperature	-10°C - +50°C
Alarm current	30mA (at 18V)	Storage temperature	-10°C - +55°C
Activation signal	Red light	Sensitivity	EN 54-5 Class A2
Remote indicator	Si	IP protection	IP20
Coverage area	52m ² (subject to local regulation)	Installation height	6m (subject to local regulation)



C50ZSL



C50ZSD

C50ZSL C50ZSD

ALARM DEVICES

Conventional alarm devices certified EN 54-23 and EN 54-3

Base for C50 conventional detectors with EN 54-23 certified visual alarm base and EN 54-3.

There are 2 models available (detector not included):

- C50ZSL: D50 base with sound and light base, addressable.
- C50ZSD: D50 base with sound, addressable.

Typical uses of the C50ZSL and C50ZSD are spaces that require integrated fire detection equipment with sounder and visual alarm, such as hotel rooms fitted out for clients with hearing impairments, waiting rooms, nursing rooms, etc.

The coverage of the assembly should not exceed the coverage of the fire detector with which it is installed, unless there is a reason or use that justifies it.

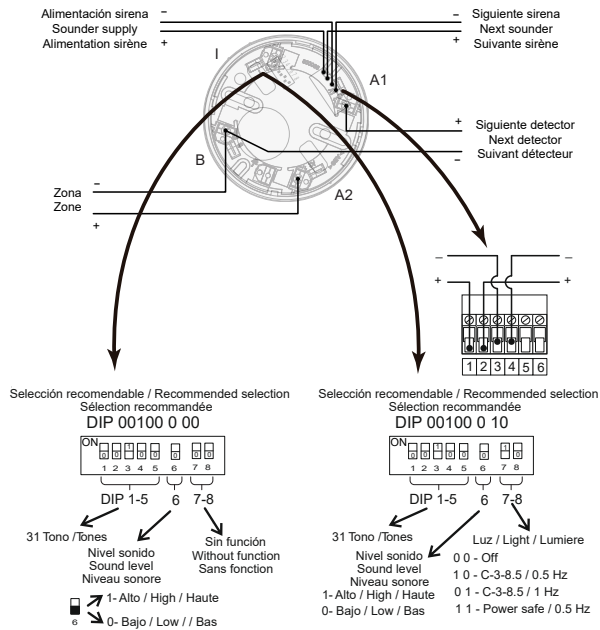

TECHNICAL FEATURES		
	C50ZSD	C50ZSL
Supply	18 - 30V with polarity	
Standby consumption	0mA	
Alarm consumption	5mA / 6mA (Low/High dB)	19mA / 20mA (Low/High dB)
Operative temperature	-10°C - +55°C	
Dimensions	Ø112x43mm (without detector)	
IP protection	IP21C	
Sound intensity	Low 90 / High 96 dB - 1m	
Tones	31 types	
Standard	EN 54-3	EN 54-23 and EN 54-3
Flash	-	0,5Hz (60ms)



PIAL

REMOTE INDICATOR

Remote action indicator for fire detection systems

Remote action indicator of fire detection system.

The PIAL allows showing detectors alarm status of the fire detection system.

Typical cases of use:

- Places where elements of the detection system are not visible, for example, inside false ceiling, in which the PIAL can be visibly situated on the lower part of the ceiling or near the wall.

- Reduced accessibility rooms or that is needed do a big inspection range for the identification of the element in alarm, for example in hotel rooms, where the PIAL can be situated above the door frame of each room, making very easy its identification.

Permanent activation of the red LED indicates alarm status.

It is an element easy to install, both for its electrical wiring and its fixation, furthermore, can be adapted to the conduit boxes and switchgear.

FEATURES

- Alarm status can be identified in any perpendicular direction at its installation.
- Easy connection, with polarity.
- Can be adapted to the conduit boxes and switchgear.
- The red light is produced by two LEDs, increasing reliability against failure of any of them.
- Manufactured in heat-resistant ABS. Base and lid are white, red viewer.

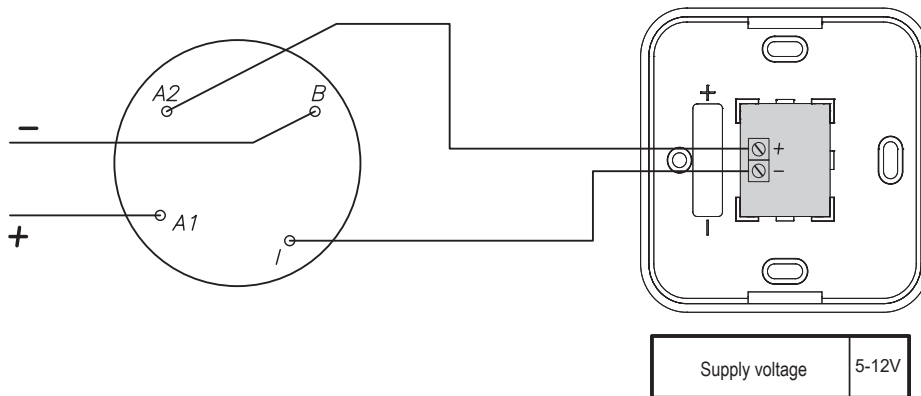

TECHNICAL FEATURES

Supply	5 - 12V/DC with polarity	Humidity	20 - 95%RH
Standby consumption	0mA	Temperature	-10°C - +50°C
Alarm consumption	5mA	IP protection	IP50
Activation signal	Red led		





DETECTION COMPLEMENTS

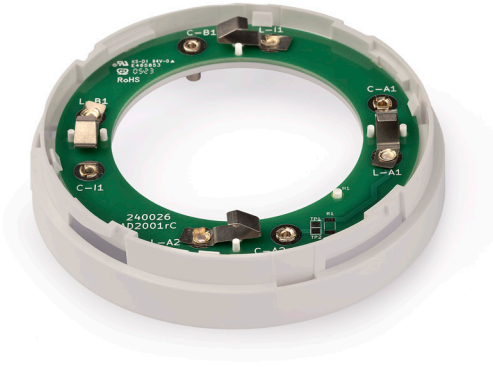

A50BI

SOCKET ADAPTER

Socket for adapting the A50 and A30X range

To facilitate the task of updating the A30X system to the new A50 range detectors, Cofem has an "interconnection base" that allows for placing the detectors of the algorithmic-addressable and conventional system directly on the sockets of higher systems without the need to change or rewire the sockets.

Thus, if the wiring and the sockets of the installation are in good condition, a quick, simple and very cheap update to the system

can be carried out, based on replacing the fire detection and alarm control panel and its detectors.

The A30XBI adaptor can be used with conventional and algorithmic-addressable detectors and these are supplied configured according to the detectors to be replaced.

A50 detector

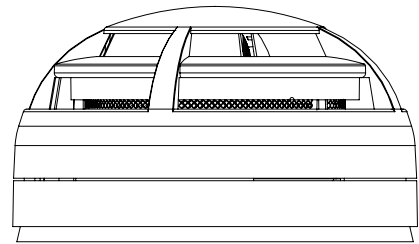
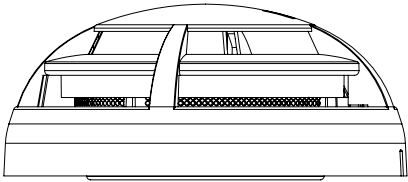

A50BI adapter

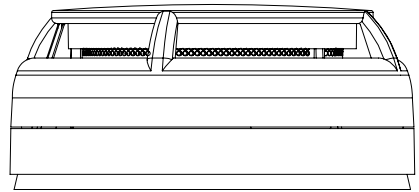
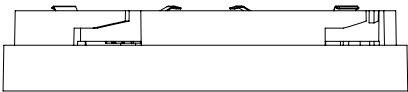

Base (A30XZO - A30XZAL)

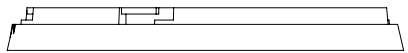

Assembly diagram

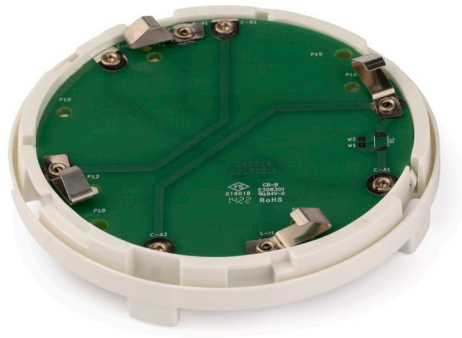

A30XBI

SOCKET ADAPTER

Socket for adapting the A30X range with previous ranges

To facilitate the task of updating the TC25/A system to the Lyon system (and in general the conventional system), Cofem has an "interconnection base" that allows for placing the detectors of the algorithmic-addressable and conventional system directly on the sockets of higher systems without the need to change or rewire the sockets.

Thus, if the wiring and the sockets of the installation are in good condition, a quick, simple and very cheap update to the system

can be carried out, based on replacing the fire detection and alarm control panel and its detectors.

The A30XBI adaptor can be used with conventional and algorithmic-addressable detectors and these are supplied configured according to the detectors to be replaced.

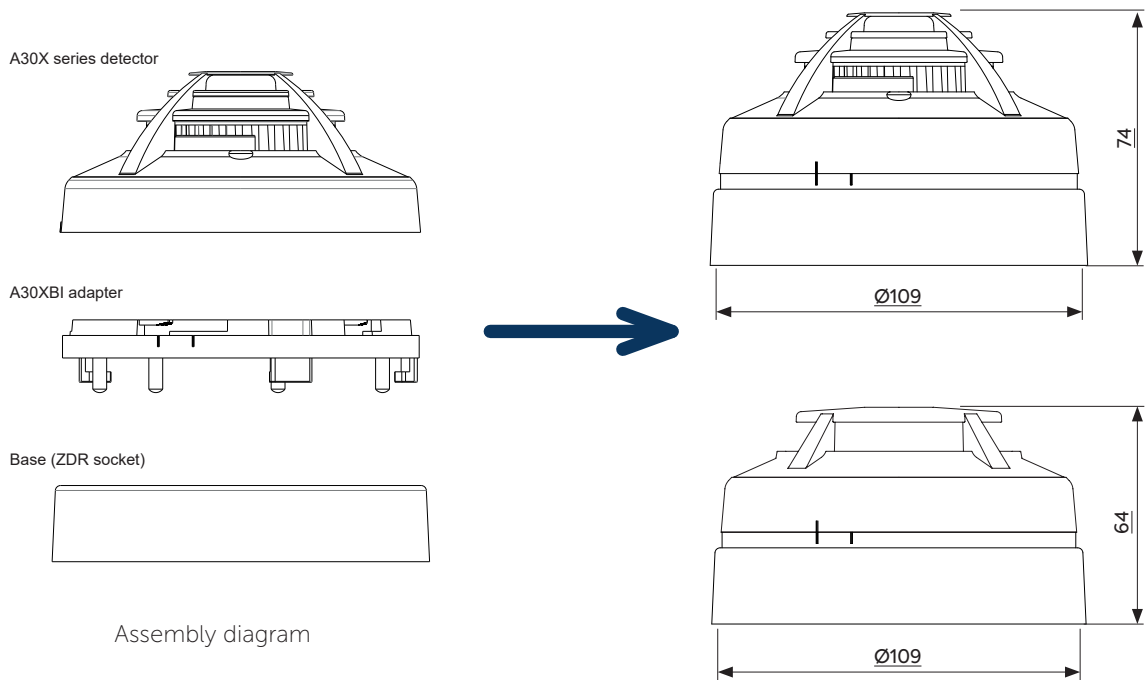

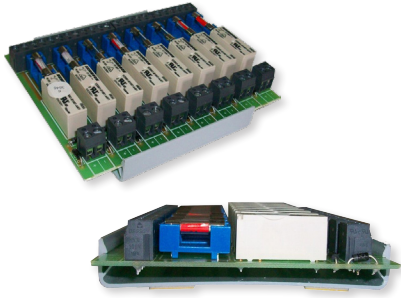

MDL1R / MDL2R MDL-8

RELAYS MODULE

Relay modules for fire detection system

Relay module for fire detection system.

This module consists of a relay that controls the output of a dry contact normally open (NO) normally closed (NC), unsupervised.

That provision allows you to control as typical application door electromagnets in conventional fire detection systems, either through the control panel supply or sources of external power supply (FAE).

The equipment is very simple and easy to install.

The board of the relay module is mounted on a plastic base, which carries some tapes that allow secure comfortably in the

place that best suits, taking advantage of the available space in stations, power supplies (FAE), etc, according to the normal distribution of the wiring of the installation.

In addition, the relay module contains a safety fuse on the side of the dry contact.

There are three versions of modules based on the number of relays contained on the base:

- MDL1R: 1 relay module.
- MDL2R: 2 relays module.
- MDL-8: 8 relays module.

FEATURES

- Relay with dry contact output NO-NC, not supervised.
- Simple installation by means of adhesive tapes, taking advantage of the space and following the normal distribution wiring.
- It contains safety fuse.

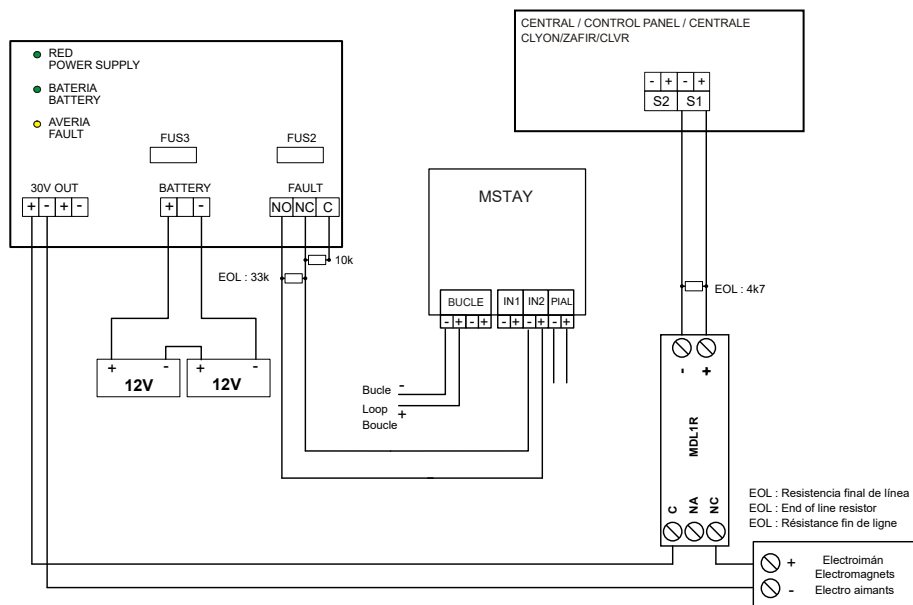

TECHNICAL FEATURES

Supply	24-35V	Consumption active	20mA
Standby consumption	0mA	Dry contact output	30Vdc / 230Vac 2A
Fuse	2A		



CAEC

OUTDOOR SOUNDER

Outdoor sounder certified EN 54-3

OUTDOOR SOUNDER CAEC

- Outdoor red sounder made in ABS plastic.
- Internal cover to protect all pcb's
- 24V power sounders.
- Piezoelectric speaker.
- EN54-3 type B certified.

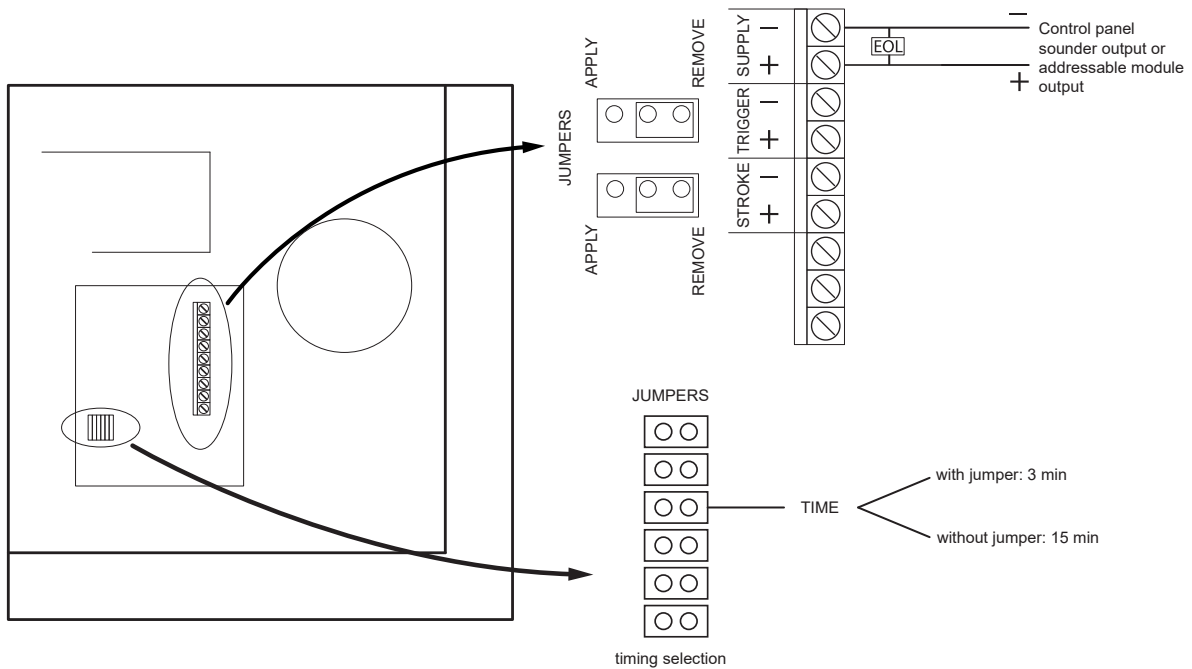

NOTE:

EOL: 33KΩ supply by addressable algorithmic modules.
 EOL: 4K7 Cofem fire control panel sounder general output.

TECHNICAL FEATURES			
Activation	Via power supply application	LED's	1 led bar
Supply	24Vcc	Dimensions	260x275x55mm
Power	92dB	Current / consumption	200mA
Timing by cycle	3/15 minutes	IP protection	IP44



CA6 / SIR24F SIR24P

INDOOR SOUNDERS

Indoor sounders for fire protection installations

Indoor sounders to be directly connected to the output of control panels or relay modules.

ACOUSTIC GENERAL RULES

- Every time you double the distance, 6 dBs are lost.
- 30 dBs are lost for every fire door.
- 20 dBs are lost for every normal door.

Sound level (dB-(A))	Distance (m)
120	1
114	2
108	4
102	8
96	16
90	32
84	64

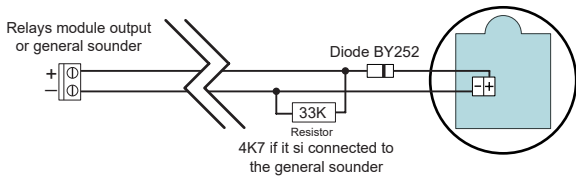
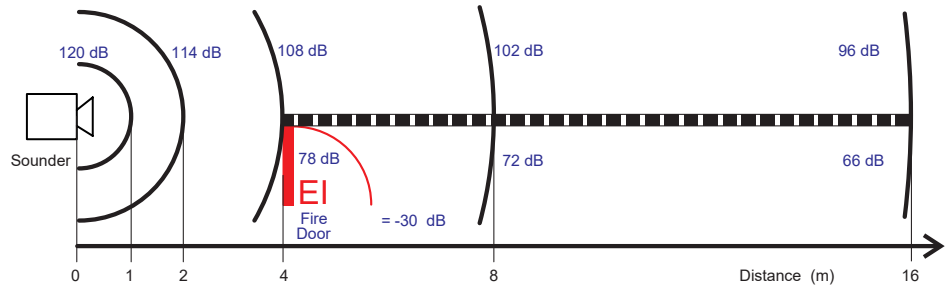

Wiring diagram CA6

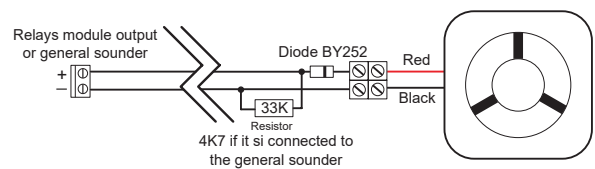

Wiring diagram SIR24P and SIR24F

TECHNICAL FEATURES			
6" ALARM BELL CA6		SIR24P & SIR24F SOUNDERS	
Operating voltage	24Vcc	Material	Red P.V.C.
Consumption	25mA	Operating voltage	30Vdc
Output volume	95dBA at 1 meter	Consumption at 30Vdc	70mA
	92dBA at 1 meter (EN 54-3)	Sound level	85dB
Operative temperature	-20°C to 60°C	Operative temperature	5°C to 40°C
Humidity	Max. 90% RH	Dimensions	80x80x30mm
Dimensions	6" (150x56mm)	With intermittent flash	Only SIR24F
Weight	850g		
IP protection	IP21		



SIR24B / SIR24BL SIR24B+BSLC SIR24C SIRENC / SIRENCL SIRENCB INDOOR AND OUTDOOR SOUNDERS

Indoor and outdoor sounders for fire protection installations

Series of indoor and outdoor sounders to be connected directly to the sounder output of the control panels or relay modules.

FEATURES

SIRENA SIR24B, SIR24BL, SIR24BZA, BSLC, SIRENC, SIRENCL and SIRENCB

- Indoor and outdoor sounder made of red ABS.
- Great sound level. Low consumption.
- Certified EN54-3.
- 32 selectable tones. Volume control.
- SIR24B: Sounder.

- SIR24C: Sounder with light, certified EN54-23.
- SIR24BL: Sounder with light.
- SIR24BZA: Sounder with high base.
- BSLC: Base with light, certified EN54-23.
- SIRENC: Sounder.
- SIRENCL: Sounder with light, certified EN54-23.
- SIRENCB: Sounder with light.
- All sounders have a diode incorporated.

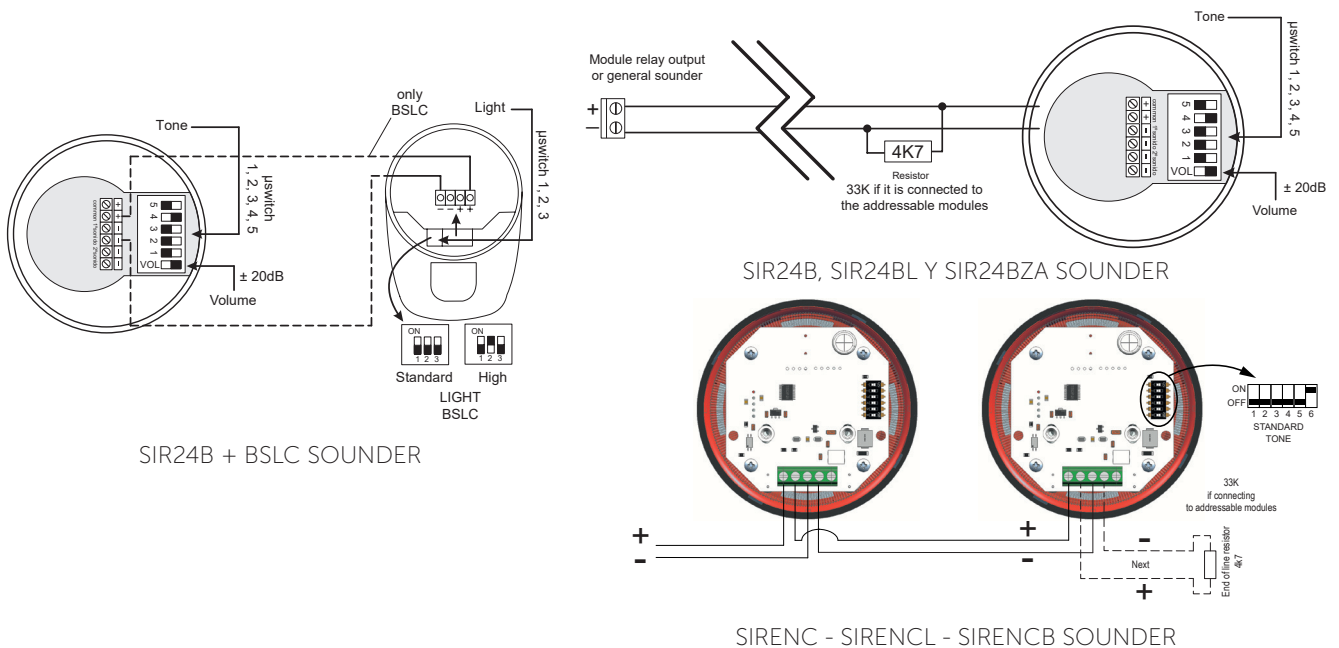

TECHNICAL FEATURES

Supply		IP protection	
SIR24B / SIR24BL / SIR24B+BSLC	9-28Vdc	SIR24B	IP54
SIR24C	24-29Vdc	SIR24BL / SIR24BZA	IP65
SIRENC / SIRENCL	12-30Vdc	SIR24B + BSLC	IP65
Consumption		SIR24C (low base)	IP21C
SIR24B / SIR24BL (tone 3)	15mA - 102dB - 24Vdc	SIR24C (high base)	IP65C
BSLC	10-25mA - W2,5-2,5/7,5 - 24Vdc	SIRENC / SIRENCL / SIRENCB	IP65
SIR24C (tone 2)	25mA - 102dB - 24Vdc Coverage 0	Dimensions	
SIRENC	25-35mA - 24Vdc	SIR24B	
SIRENCL	45-65mA - 24Vdc - W2,4-1,2/W3,2-6,8	Ø95x91mm	
SIRENCB	10-26mA - 24Vdc - >4cd		



SIR24SC



SIR24SLC

SIR24SC SIR24SLC

VOICE ALARM DEVICES

Voice alarm devices for fire protection installations

Voice alarm device

Device that activates a voice message with sound of fire alarm.
The message is selectable from its internal list.
They have a diode incorporated.

A. SIR24SC and SIR24SC+SIR24SLC:

- Voltage: 18 ÷ 28 Vdc.
- Consumption: 4 ÷ 8 mA.
- Sound: 90/100 dB selectable.
- Several selectable alarm tones.
- Temperature: -10°C a 55°C.
- Protection: IP21C.
- Colour: red.
- Dimensions: 106 x 106 x 91mm.

B. SIR24SC + SIR24SLC:

Set alarm voice with bright warning based device.

- Certified EN54-23.
- W 2,4 - 7,5.
- Consumption: 18 ÷ 28 mA.
- 1 Hz (0,5 Hz selectable).

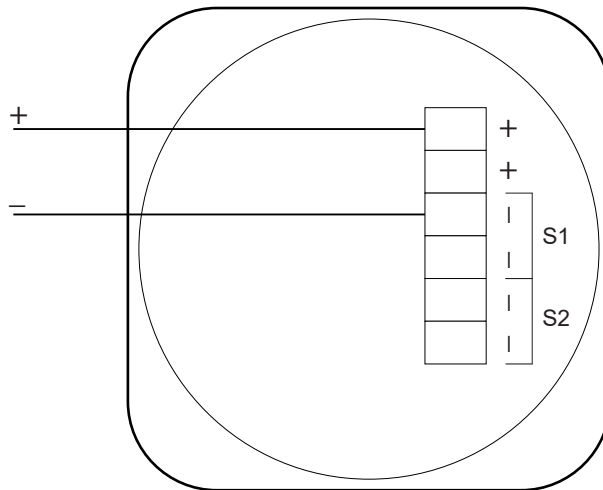

Diagram for SIR24SC



SIRCEI / SIRWAL SIR-PIT

LIGHT WARNING DEVICES

Light warning devices for fire protection installations

Luminous warning devices:

Devices that when are activated emit flashes of light in order to alert people with hearing disabilities:

A. SIRWAL and SIRCEI:

- Certified EN54-23.
- Supply: 9 ÷ 60 Vdc.
- Operating temperature: -25°C to 70°C.
- High base.
- Protection IP65.
- Red colour.
- Dimensions: Ø93 mm x 65 mm.
- Flash: White 1Hz (0,5 Hz selectable).
- Consumption: 10-25 mA according selection.
- They have a diode incorporated.

A1. SIRWAL:

- Wall device.
- W 2,4 - 7,5.

A2. SIRCEI:

- Ceiling device.
- C 3 - 7,5.

B. SIR-PIT:

- Supply: 9 - 60 Vdc.
- Consumption: 3 ÷ 15 mA according selection.
- Flash:
 - 1 flash 1Hz.
 - 2 flashes 1Hz.
 - Continuous 1Hz.
- Temperature: -20°C to 55°C.
- Protection: IP21C.
- Colour: red.
- Red flash.

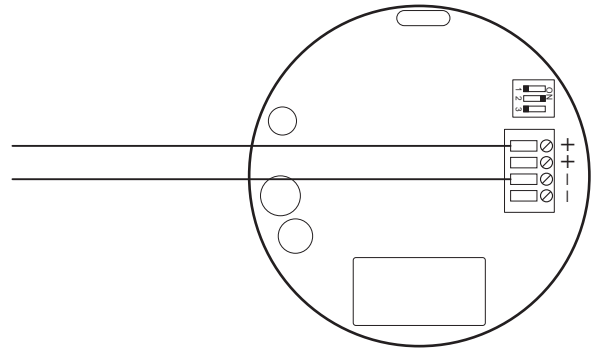

Diagram for SIRWAL and SIRCEI

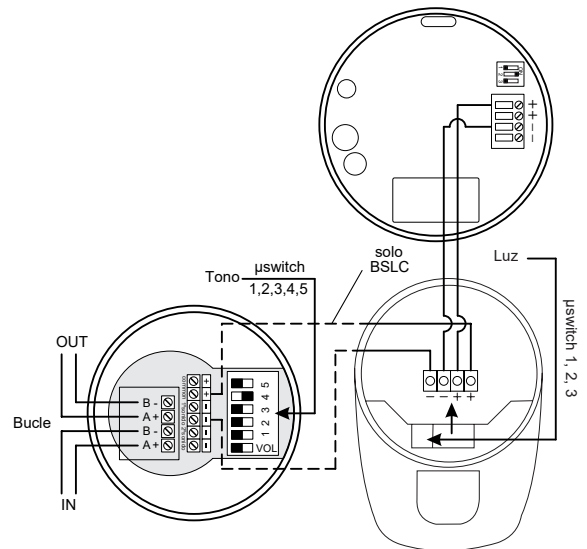

Diagram for SIRWAL and SIRCEI with BSLC and SIRAY

NOTE: They can be connected with the SIRAYBSLC by selecting low sound and light on this device and BSLC. The calculation of consumption points of the SIRAY+BSLC and this additional device shall be computed as a SIRAY+BSLC with selection of sound and maximum light.



PWS03Y/05Y

EXTERNAL POWER SUPPLY

External power supply for fire protection installations

External switched-mode power supply.

There are 2 models depending on the system's power requirements:

- PWS03Y: 3A (100W) supply capacity.
- PWS05Y: 5A (155W) supply capacity.

The PWS is offered installed inside a 424x330x160mm (with cover), which provides additional space for the necessary batteries inside.

FEATURES

- Supply capacity of 3A (PWS03Y model) or 5A (PWS05Y model).
- PWS incorporated in a cabinet, which allows the necessary batteries to be installed inside it.
- Metallic cabinet.
- Incorporated battery charger
- Existing variant with black cabinet and grey door (PWS03 / PWS05).

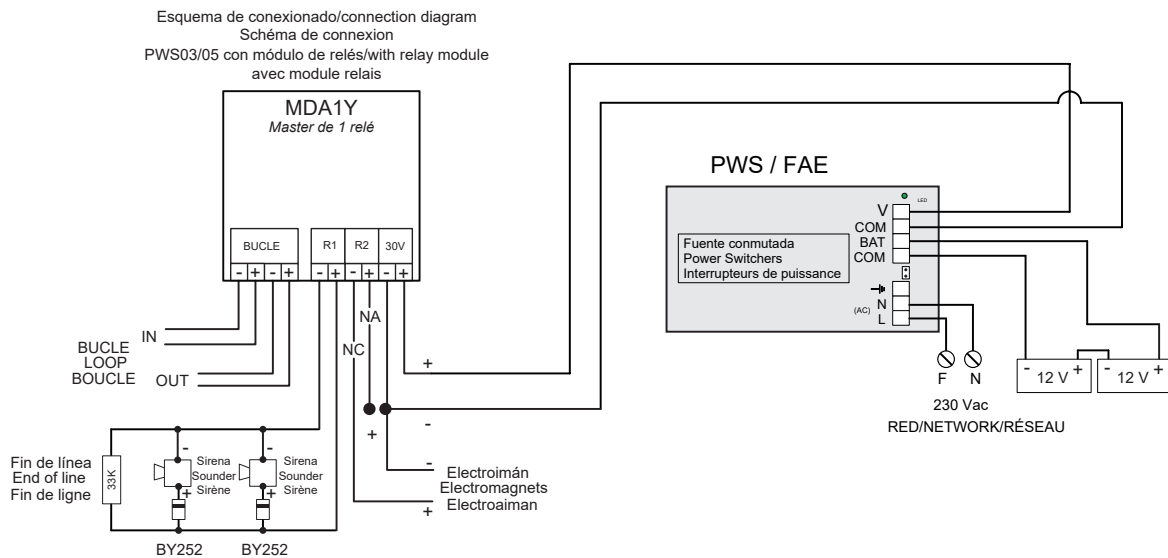

TECHNICAL FEATURES

Supply	230V/AC 50Hz	Humidity	20-95%RH
Output voltage	30V/DC	Temperature	-10°C a +50°C
Standby consumption	100mA	Dimensions	424x330x160mm (with cover)
Output current	FAE03: 3A / FAE05: 5A	IP protection	IP30
Battery charger	Yes		



ZAFIRPWS2-ZAFIRPWS5



ZAFIRPWS2Y-ZAFIRPWS5Y

ZAFIRPWS

EXTERNAL POWER SUPPLY

External power supply for fire protection installations

External Power Supply (with batteries charge incorporated) for fire detection and fire alarm systems. Certified according EN 54-4.

This equipment is specially recommended for properly feeding any fire detection device which requires external power supply.

It has two outputs:

30V output monitored and protected by a fuse, for easy connection.

Dry contact fault output, for integration with other systems.

The system has three indication leds to show system status:

RED (green): system operating through 110/230 V/AC power supply.

BATTERY (green): system operating under batteries.

FAULT (amber): system fault, general power supply

fault or fault in the auxiliary battery supply.

There are 2 models available depending on the needs of the system:

- ZAFIRPWS2 (65W): supply capacity 1,5A (65w).
- ZAFIRPWS5 (150W): supply capacity 4A (150w).

General power supply connection is different between the two models. ZAFIRPWS2 is connected to electrical network by a connector located on the right side of the box. ZAFIRPWS5 is connected to electrical network directly to the switching power supply.

External Power Supply is placed inside a metallic box of 368x336x96mm (with cover), which allow additional space for installing batteries (2x12 Vdc7Ah).

There is a variant with white door (ZAFIRPWS02Y and ZAFIRPWS05Y).

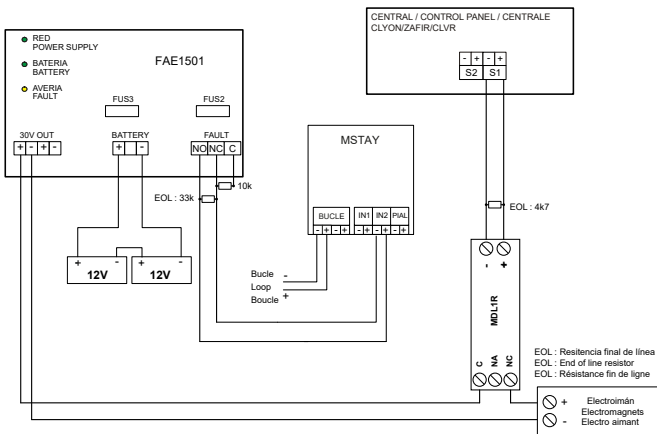

Wiring diagram ZAFIRPWS2/5
Algorithmic Addressable system

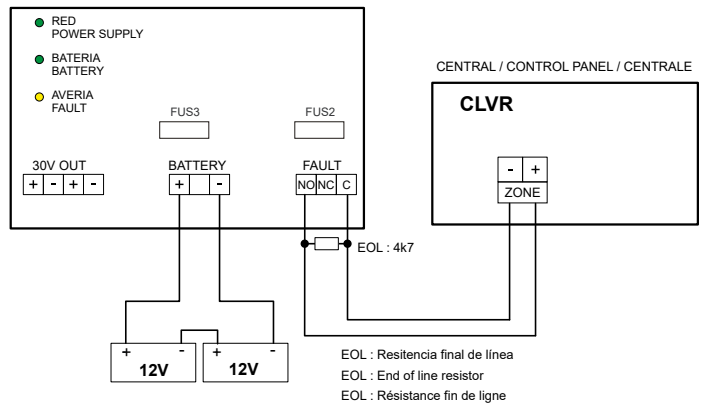

Wiring diagram ZAFIRPWS2/5 fault output

TECHNICAL FEATURES			
Power supply	110/230V 50-60Hz/AC	Humidity	20-95%RH
Consumption in standby	50mA	Temperature	-10°C to +50°C
Output voltage	29~29,5VDC	Dimensions	368x336x96mm (with cover)
Output current	ZAFIRPWS2(Y): 1,5A / ZAFIRPWS5(Y): 4A	IP protection	IP30
Batteries charger	Yes	Standard	EN 54-4



DLRCM



DLRC

DLR

SMOKE BEAM DETECTORS

Smoke beam detectors certified EN 54-12

Optical smoke beam detectors for fire detection system consisting in a system of emitting/receiving an optical beam of infra-red light.

The installation of these detectors is ideal for large premises or for premises with very high ceilings.

Models available:

- DLRCM60/120: Reflective and motorized beam detector, 4-60m or 60-120m maximum spacing, with adjustment control by mobile application.
- DLRC: Conventional beam detector between 5 to 160m. Supply from control panel or external supply. Alarm and fault output connected to zone.

CONVENTIONAL SYSTEM

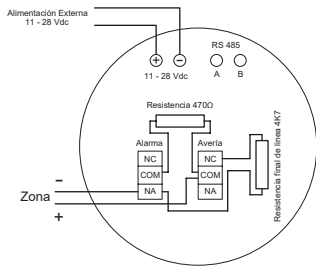

ALGORITHMIC ADDRESSABLE SYSTEM

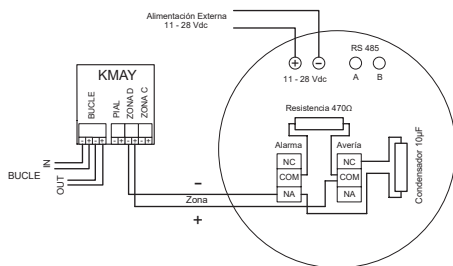

DLRCM60 / DLRCM120 connection diagram

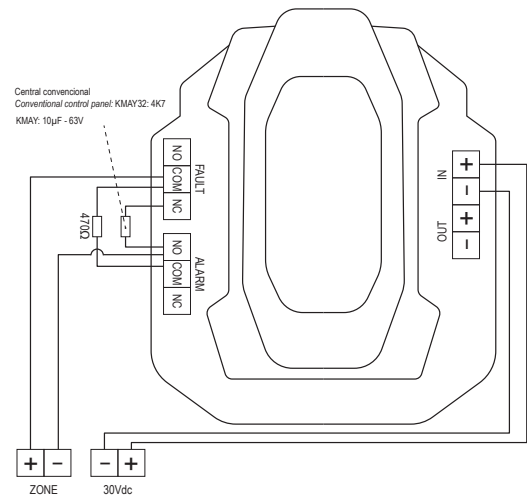

DLRC connection diagram

TECHNICAL FEATURES	
	DLRCM
Supply	11-30 Vdc
Standby consumption	6mA at standby / 30mA during alignment
Max. detector misalignment	± 0,5°
Max. reflector misalignment	± 1°
Temperature	-10°C to +55°C
Protection	IP65/IP55 according to install. method
Standard	EN 54-12

TECHNICAL FEATURES	
	DLRC
Supply	Loop 24V or DC12-24V
Standby consumption	≤20mA@DC24V
Alarm consumption	≤30mA@DC24V
Laser concentricity	≤1°@160m
Maximum misalignment angle	0,45°@160m
Temperature	-10°C to +55°C
Standard	EN 54-12



CTE / CTX

LINEAL HEAT DETECTOR

Lineal heat detector for fire protection installations

Linear heat Detector is a proprietary cable that detects the heat at any point of its length.

The sensor cable consists of two steel conductors individually insulated with a polymer sensitive to temperature. The insulated conductors are twisted together to create a spring pressure, then is wrapped with an outer cover appropriate to the environment in which must be installed in the detector.

In the calibrated temperature, heat sensitive insulating polymer yields against the pressure generated by the radiation of heat,

allowing interior conductors get in touch between them and activate an alarm signal. This action occurs at any point heated within the detector cable length. It is not required to heat a specific length to activate the alarm, or you need to calibrate the system to compensate for changes in environmental temperature where it is installed.

The linear heat Detector provides the advantages of coverage of lines with sensitivity of specific points.

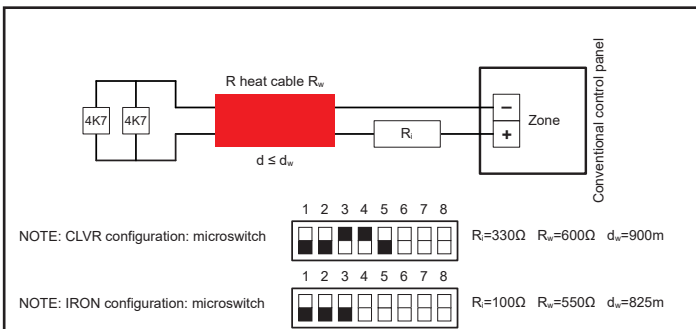

Wiring diagram with direct connection to the conventional control panel

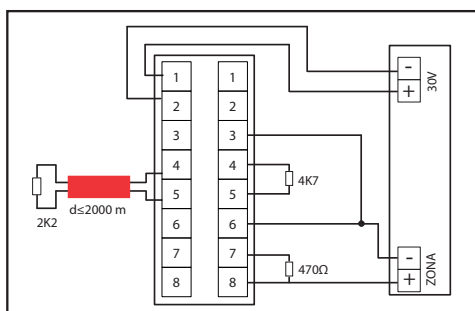

Wiring diagram with interface module

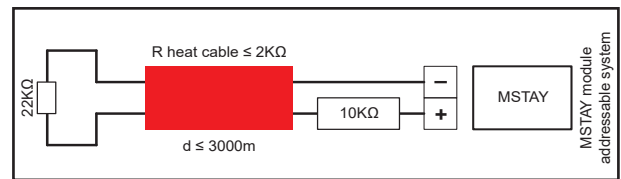

Wiring diagram with direct connection to addressable module MSTAY

Product type	Alarm T°C	Max environ.T°C
EPC Various utilities/ Industrial and commercial applications	68 °C	38 °C
	78 °C	56 °C
	88 °C	66 °C
	105 °C	79 °C
	138 °C	93 °C
XCR Industrial applications excellent resistance to the chemical abrasion	180 °C	105 °C
	68 °C	38 °C
	88 °C	66 °C
	105 °C	79 °C
XLI Excellent for low T°C	138 °C	93 °C
	180 °C	121 °C
	57 °C	38 °C

Temperature and product type evaluation

TECHNICAL FEATURES

Max. nominal voltage	30VAC, 42VDC
2W wire resistance	0,2 ohms / pie. (0,656 ohm / m)
Min. radius of curvatures	6,4cm
Diameter	Nominal 4mm
Weight	Nominal 3,5kg / 152m



FDINA40



FDAAT60

FDINA40 FDAAT60

FLAME DETECTOR

Flame detector for fire protection installations

Flame detector to protect zones with open fires.

The detector is designed to respond to the flicker frequency and wavelengths characteristic of flames

There are three types of detectors depending on the used sensors to centre in the typical specific wavelengths of the flames and generate algorithms to discriminate these flames

from others lightning supplies:

- IR2: 2 IR sensors
- IR3: 3 IR sensors
- UV/IR3: 1UV sensor and 2 IR sensors.

Equally, there are an ATEX and conventional version of the previous models.

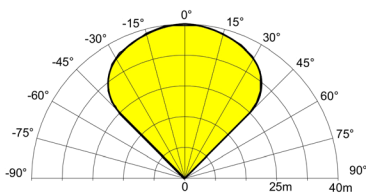

Detection field for the conventional detector

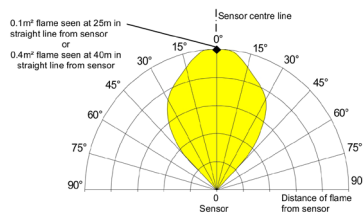

Detection field for the ATEX detector

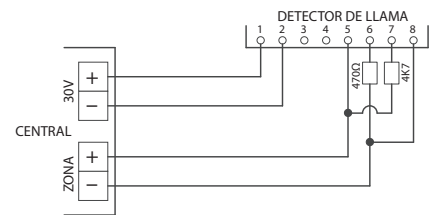

Wiring diagram

TECHNICAL FEATURES	
Supply voltage	14-30VCC
Alarm current options	28mA, RL1 y RL2 energized 20mA, current loop, RL1 and 2 off 9mA, RL1 energized
Alarm indicator	Red, light-emitting diode (LED)
Alarm reset time	1 second
View range	0,1m2 n-heplane at 25m
Sensibility	Class 1 (EN 54-10)
View field	90° cone
Spectral response	185 a 260nm UV / IR3 1,0 - 2,7um
Operating temperature / Humidity	-10°C a +55°C (without ice or condensation) / 95% RH without condensation
IP protection	IP65 (conventional) / IP66 (ATEX)
Cover material	Die-cast Zinc alloy, blue (conventional) Copper-free aluminium, red (ATEX)
Dimensions	142x108x82mm (conventional) / 150x146x137mm (ATEX)
Weight	2kg (conventional) / 2,5kg (ATEX)

DAS1T / DAS4T

ASPIRE SMOKE DETECTOR



DAS1T

DAS4T

Aspire smoke detector for fire protection installations

A range of aspirating smoke detectors .

They detect smoke by analysing the air sucked in through holes in tubes distributed around the room to be monitored and fed to this detector.

This aspiration detector uses the latest technology in detection, avoiding false alarms, particle recognition, greater stability, sensitivity and longevity.

Typical applications for this range of detectors are: Data storage rooms, air conditioning units, machine rooms, computer rooms, equipment grilles, prison cells, air ducts, etc.

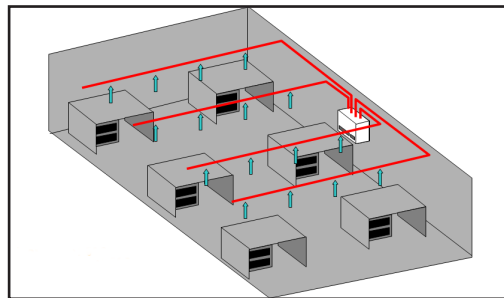

installation diagram

TECHNICAL FEATURES		
	DAS4T	DAS1T
Supply	24V nominal	24V nominal
Consumption in alarm	7,8 - 9,6W	9,6W
Operating temperature	0 - 39°C	0 - 39°C
Humidity	10% - 95% (no condens.)	10% - 95% (no condens.)
IP protection	IP40	IP40
Dimensions	350x225x135mm	350x225x135mm
Standard	EN 54-20	EN 54-20



ELPCF

ELECTROMAGNETS

Electromagnets for fire doors

ELPCF50K-ELPCF50KR-ELPCF50KAL-ELPCF50KALR ELECTROMAGNETS:

Electromagnetic wall retainers for fire containment doors.

- Power supply: 24V DC
- Consumption: 60 mA.
- Retention force: > 55 Kg | adjustable force.
- Unblocking push button.
- Noise suppressor.
- Anti-magnetic spring.
- UNE 1155 certificate.
- Head dimensions: 75x90x35 mm.

ELPCF140K ELECTROMAGNET:

Electromagnetic wall retainers for fire containment doors:

- Power supply: 24 V DC
- Consumption: 70 mA.
- Retention force: > 140 Kg.
- Unblocking push button.
- Noise suppressor.
- Anti-magnetic spring.
- EN 1155 certificate.
- Head dimensions: 90x100x43 mm.

ELPCF300K ELECTROMAGNET:

High power electromagnetic retainer for emergency and general passage doors.

- Power supply: 12 - 24V DC.
- Consumption at 12V DC: 500 mA.
- Consumption at 24V DC: 250 mA.
- Retention force: 300 Kg.
- With damping.
- Operating temperature: -10°C to +50°C.
- Protection: IP40.
- Dimensions: 250x48x25 mm.

ELPCF600K ELECTROMAGNET:

High power electromagnetic retainer for emergency and general passage doors.

- Power supply: 12 - 24V DC.
- Consumption at 12 V DC: 500 mA.
- Consumption at 24 V DC: 250 mA.
- Retention force: 600 Kg.
- Dimensions: 265x66x41 mm.

ELPCF50KS ELECTROMAGNET:

Electromagnetic retainer for mounting on the floor.

- Power supply: 24V DC
- Consumption: 45 mA.
- Retention force: 50 Kg.
- Protection: IP40.



Compositor Wagner, 8,
P.I. Can Jardí, 08191 Rubí,
Barcelona

(+34) 935 862 690
www.cofem.com | cofem@cofem.com